



THE ART OF THE ANTIQUE DRAPERY ROD
WITH CONTEMPORARY HARDWARE & TEXTILE SOLUTIONS
AND PERIOD MUSIC
4TH CENTURY BC TO 19TH CENTURY AD
WHITNEY A. WALKER

This book is dedicated to my Father
Richard K. Walker
and his deep belief that everything good is possible
with hard work and creativity.

Graphics by J. L. Cominolo
Second Edition

cover photo: image 6; Empress Theodora "Empress Regent" Byzantine Empire, 535 to 548

TABLE OF CONTENTS

| | | |
|------------|------------------------------------|--|
| Page 5 | Music Credits | |
| Image 1 | 4th Century BC | Phlyax Vase, Greek, Paestum |
| Image 2 | Augustus period | Marble, Cushion and soft furnishings store, Rome |
| Image 3 | 2nd Century | Wall Painting, Pompeii |
| Image 4 | 3rd Century | Sarcophagus of Father |
| Image 5 | 4th Century | Fresco of Samson |
| Image 6 | 6th Century | Ivory Carving of an Empress, Byzantine |
| Image 7 | 6th Century | Mosaic of Empress Theodora, Byzantine |
| Image 8 | 7th Century | Illumination, Lindisfarne Gospel |
| Image 9 | 7th Century | Mosaic of Constantine IV, Byzantine |
| Image 10 | 9th Century | Ivory carving of St Gregory |
| Image 11 | 10th Century | Ivory plaque of Otto II and Theophrano |
| Image 12 | 12th Century | Vellum, Ecstasy of St. Gregory |
| Image 13 | 14th Century | Vellum, The Extreme Unction |
| Image 14 | 14th Century | Fresco, Stories of Virgin Mary |
| Image 15 | 14th Century | Vellum, Nicolas Oresme presents his work on Aristotle |
| Image 16 | 15th Century | Tempera on panel, Miracle of Deacon Justinian |
| Image 17 | 15th Century | Oil on canvas, Madonna and Child by Bellini |
| Image 18 | 16th Century | Portrait of Erasmus by Hans Holbine the Younger |
| Image 19 | 16th Century | Tapestry, Birth of St. John |
| Image 20 | 17th Century | Holy Family with Curtain by Rembrandt van Rijn |
| Image 21 | 17th Century | Oil on canvas, Girl at Window Reading a Letter by Jan Vermeer |
| Image 22 | 18th Century | Lansdown Tower - The Scarlet Drawing-Room |
| Image 23 | 19th Century | Moresque Interior, from "Album of a Voyage to Spain, Morocco and Algeria" by Ferdinand Victor Eugene Delacroix |
| Image 24 | 19th Century | Oil on card, Reading by the Window by Charles James Lewis |
| Page 54 | Iron Works | |
| Page 56-63 | Suggested Hardware | |
| Page 70 | Art Credits | |
| Page 71 | About the author, Whitney A Walker | |

Music Credits

| Image | Title | Artist, Album, Song and Link | | |
|-------|---|-------------------------------|---|--|
| 1 | Phlyax vase depicting Dionysus | Michael Levy | The Ancient Greek Lyre | The First Delphic Hymn To Apollo 138 BCE https://itunes.apple.com/us/album/the-ancient-greek-lyre/id393321464 |
| 2 | Cushion and Soft Furnishing store | Synaulia | Synaulia, Music from Ancient Rome - Volume 1 Wind Instruments | Fortuna https://itunes.apple.com/us/album/music-from-ancient-rome-vol./id74419588 |
| 3 | Shrine of the household gods | Synaulia | Synaulia, Music from Ancient Rome - Volume 2 String Instruments | The Villa of Mysteries https://itunes.apple.com/us/album/music-from-ancient-rome-vol/id91042805 |
| 4 | Front side of sarcophagus | Synaulia | Synaulia, Music from Ancient Rome - Volume 2 String Instruments | Syriac Dance https://itunes.apple.com/us/album/music-from-ancient-rome-vol/id91042805 |
| 5 | Battle between Samson & Philistines | Synaulia | Synaulia, Music from Ancient Rome - Volume 2 String Instruments | Cithara and Sambuca https://itunes.apple.com/us/album/music-from-ancient-rome-vol/id91042805 |
| 6 | Relief carving of an Empress | Costas Zorbas | Byzantine Music of the Greek Orthodox Church - The Akathist Hymn B' Ave Maria | 3rd Stanza (N-S) https://itunes.apple.com/us/album/volume-7-akathist-hymn-b-ave/id281857389 |
| 7 | Empress Theodora | Costas Zorbas | Byzantine Music of the Greek Orthodox Church - The Akathist Hymn B' Ave Maria | 4th Stanza (T-Z) https://itunes.apple.com/us/album/volume-7-akathist-hymn-b-ave/id281857389 |
| 8 | Gospel of St. Matthew, Lindisfarne | Gregoria Chant scola | Gregorian Chants of St. John's Abbey | Hymnis angelicis https://itunes.apple.com/us/album/singing-mary-saints/id722281831 |
| 9 | Constantine IV | Capella Romana | Music of Byzantium | Kanon in Honor of St Thomas Aquinas https://itunes.apple.com/us/album/music-of-byzantium/id278563699 |
| 10 | St. Gregory writing | Bernard Fabre | Missa Pange Lingua & Motets by J. Desprez | Plain - Chant: Pange lingua https://itunes.apple.com/us/album/j.-desprez-missa-pange-lingua/id815566421 |
| 11 | The Crowning of Otto II | Costas Zorbas | Byzantine Music of the Greek Orthodox Church, Hymn of Vespers. V 1 | Ascending & 2 choir Hymns https://itunes.apple.com/us/album/volume-1-hymns-vespers-matins/id281857202 |
| 12 | The Ecstasy of St. Gregory | Anonymous 4 | Hildegard von Bingen: 11,000 Virgins | Benedicamus domino https://itunes.apple.com/us/album/hildegard-von-bingen-11-000/id586077828 |
| 13 | The Extreme Unction | Hillard ensemble | Guillaume de Machaut: Motets | De Souspirant Cuer, M2 https://itunes.apple.com/us/album/guillaume-de-machaut-motets/id110430756 |
| 14 | Stories of Virgin Mary | L'Homme Arme & Fabio Lombardo | Regina Pretiosa: Una Celebrazione Mariana del Trecento Firointino | Regina Pretiosa https://itunes.apple.com/us/album/regina-pretiosa-una-celebrazione/id652526136 |
| 15 | Nicolas Oresme presents work to Charles V | Alba Musica Kyo | Marchaut and His Time: 14th Century French Ars Nova | Doulz Viaire Gracieus https://itunes.apple.com/us/album/marchaut-his-time-14th-century/id270321961 |
| 16 | Miracle of the Deacon Justinian | Francis Biggi, Ars italica | Musica del XV Secolo in Italia | Rostiboli Gioioso https://itunes.apple.com/ie/album/musica-del-xv-secolo-in-italia/id666844859 |
| 17 | Barbarigo Altarpiece | Francis Biggi, Ars italica | Musica del XV Secolo in Italia | Salve, virgo regia https://itunes.apple.com/ie/album/musica-del-xv-secolo-in-italia/id666844859 |
| 18 | Portrait of Erasmus | Charles Daniels & Fretwork | Ludwig Senfl | Im Maien https://itunes.apple.com/us/album/ludwig-senfl-im-maien/id586114456 |
| 19 | Visitation, Birth & Circumcision of St John | Markus Tapio | Barzellette - North Italian Frottole of the Early 16th Century | Recerchar secondo (for Viola da Gamba) https://itunes.apple.com/us/album/barzellette-north-italian/id815633965 |
| 20 | Holy Family with a Curtain | Peter Ouwerkerk | Rembrandt, music of his time | Tablatuur-boeck van pasalmen en fantasyen: Psalm XXIV https://itunes.apple.com/ca/album/art-music-rembrandt-music/id457799549 |
| 21 | Girl at a Window Reading a Letter | Camerata Trajectina | Huygens: Dutch Music in the 17th Century | Courante https://itunes.apple.com/us/album/huygens-dutch-music-in-17th/id263483188 |
| 22 | Lansdown Tower | Alfred Brendel | Mozart: Piano Concertos K.271 | Jeunehomme https://itunes.apple.com/us/album/mozart-piano-concertos-k.271/id4673642 |
| 23 | Moresque Interior | Various artists | Morocco (Sounds from an Ancient Land) | Gullu Bent Halima https://itunes.apple.com/us/album/morocco-sounds-from-ancient/id83065315 |
| 24 | Reading by the Window | Joan Sutherland | La Stupenda - Joan Sutherland, John Field | The Boheimium Girl https://itunes.apple.com/ie/album/la-stupenda-supreme-joan-sutherland/id116981753 |

Image 1

Date 4th Century BC

Title Phlyax vase depicting Dionysus watching performance of acrobat and farcical actors, by Assteas, Italiot red-figure pottery, from Paestum, Campania, Italy, 4th Century BC

Description Phlyax vase depicting Dionysus who attend the performances of an acrobat and two farcical actors, by Assteas, Italiot red-figure pottery, from Paestum, Campania, Italy. Ancient Greek civilization, Magna Graecia, 4th Century BC.

Location Lipari, Castello Museo Archeologico Regionale Eoliano Luigi Bernabo' Brea (Archaeological Museum)

Period Hardware The Antique Drapery Rod Company Inc., Glossary page 56

Period Textiles Possibly hand woven linen. In a Greek draping style.

Period Music The Ancient Greek Lyre by Michael Levy

Music Link The First Delphic Hymn To Apollo 138 BCE
<https://itunes.apple.com/us/album/the-ancient-greek-lyre/id393321464>

Notes: 4th Century BC, an early example of wall draping, swagged or attached high on the wall. A contemporary treatment. Could be tacked or gathered and swagged with hand forged iron rings shown below.

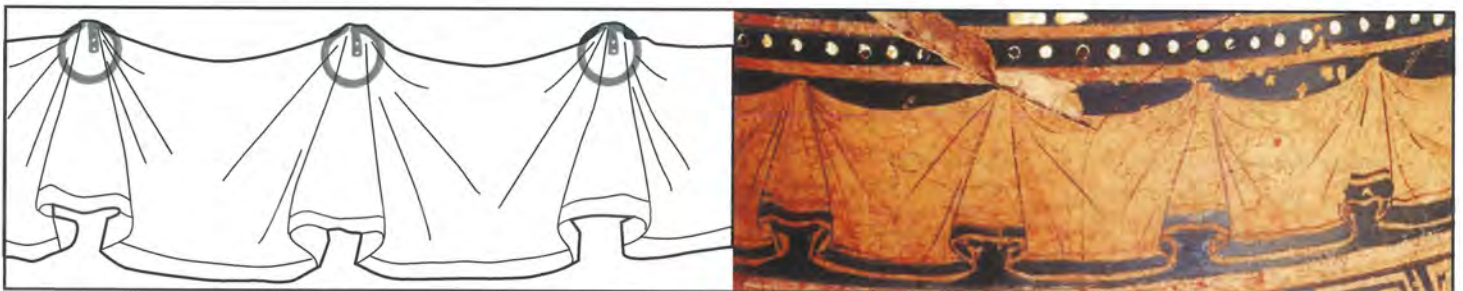



image 1

Image 2

Date Augustan Period, 27 BC to 14 AD

Title Cushion and Soft Furnishing store in Italy during the Augustan period (marble)

Creator Roman

Description shop selling cushions, curtains, curtain loops, draperies; negozio di un mercante di cuscini; marchand de coussins;

Location Galleria degli Uffizi, Florence, Italy

Medium marble

Period Hardware The Antique Drapery Rod Company Inc., Glossary page 56

Period Textiles Textile shown most likely hand woven linens, Indian cotton and wools

Period Music Synaulia, Music from Ancient Rome - Volume 1 Wind Instruments

Music Link Fortuna

<https://itunes.apple.com/us/album/music-from-ancient-rome-vol./id74419588>

Notes: Today, 2,000 years later, people are standing in a store buying and selling very similar creature comforts necessary to the human condition. I believe textiles to be a 6th element after the 5 classical elements of earth, water, air, fire and æther (or Akasha, Spirit). Almost all human spaces from ancient caves and cottages, to the most modern and severe architecture require some form of woven textiles as a layer between the body and the building.

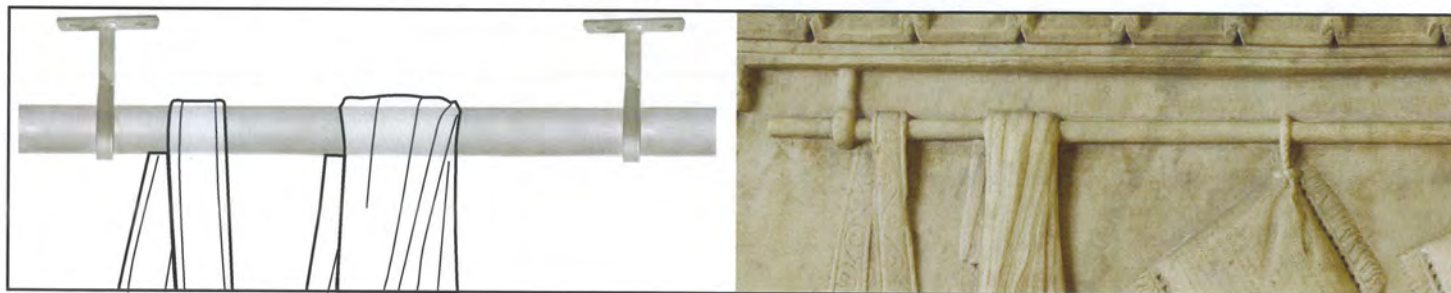

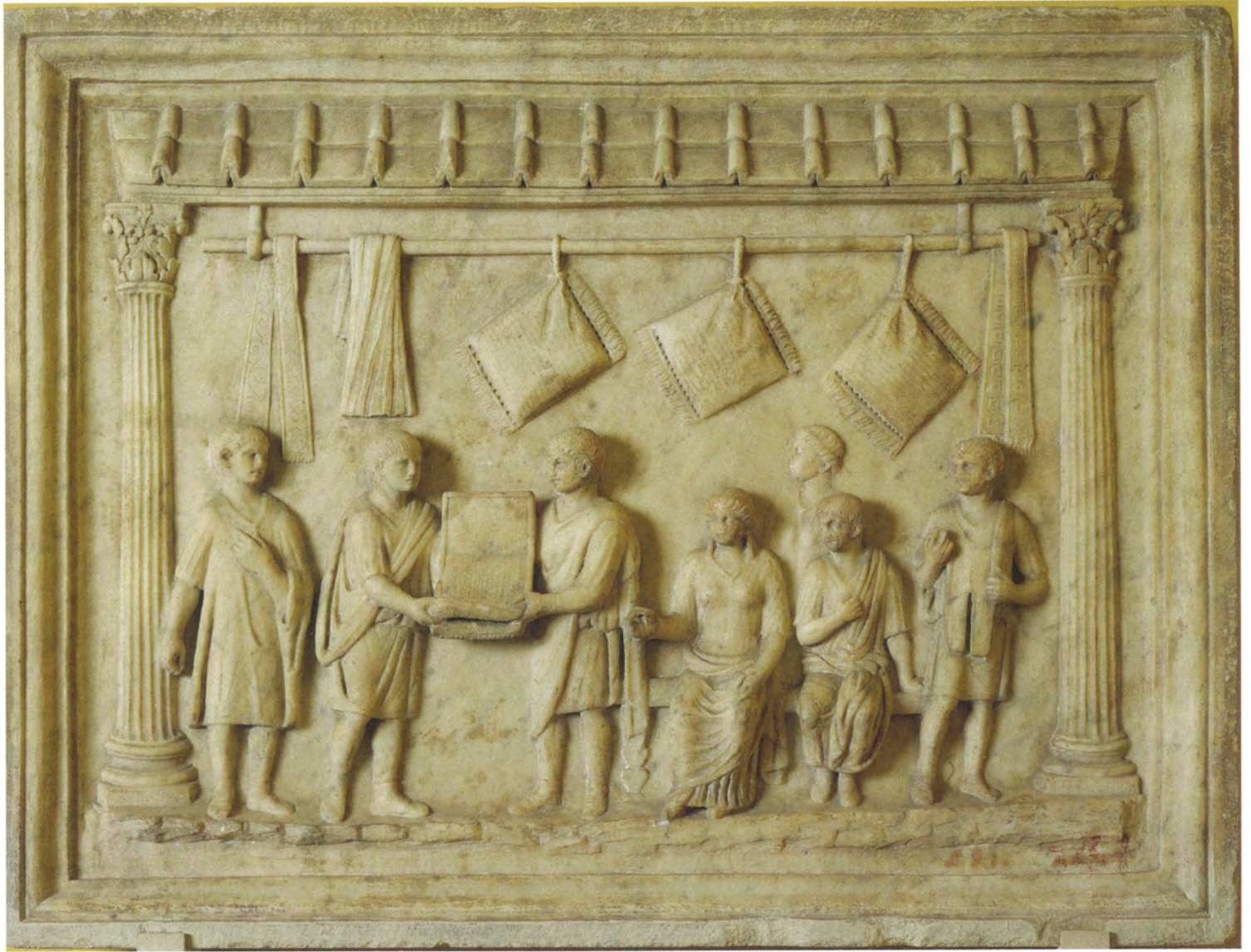

image 2

Image 3

Date 1st Century, 79 AD

Title Shrine of the household gods in an atrium of the House of the Vettii, Pompeii

Description In the centre stands the Genius, his head veiled appropriately for offering a sacrifice He is flanked by two Lares Country of Origin Italy Culture Roman Place of Origin Pompeii

Location Galleria degli Uffizi, Florence, Italy

Period Hardware The Antique Drapery Rod Company Inc., Glossary page 56

Period Textiles Garland of fresh leaves, possibly eucalyptus, laurel or olive leaves

Period Music Synaulia, Music from Ancient Rome - Volume 2 String Instruments

Music Link The Villa of Mysteries

<https://itunes.apple.com/us/album/music-from-ancient-rome-vol/id91042805>

Notes: Greco Roman draping of garland was used in celebration, in spiritual rites and as a natural air freshener.





image 3

Image 4

Date 3rd Century

Title Front side of sarcophagus depicting father surrounded by his family, Detail

Description Roman civilization, 3rd century A.D. Front side of a sarcophagus. Father surrounded by his family. Detail.

Location Paris, Musée Du Louvre

Medium marble

Period Hardware The Antique Drapery Rod Company Inc., Glossary page 57

Period Textiles Possibly hand woven linen or Indian cotton.

Period Music Synaulia, Music from Ancient Rome - Volume 2 String Instruments

Music Link Syriac Dance

<https://itunes.apple.com/us/album/music-from-ancient-rome-vol/id91042805>

Notes “Wall draping” or “Antique Draping” is an ancient decoration of loose curtains covering all the walls. The draping was attached by nail, peg, swag or medallion. Different than “tent draping” which included a fabric draped ceiling. Popular with architects and designers thru history, palaces in Naples, Rome and Berlin, Napoleon’s home at Malmaison, George IV interiors at Carlton House, Stanford White and Billy Baldwin..

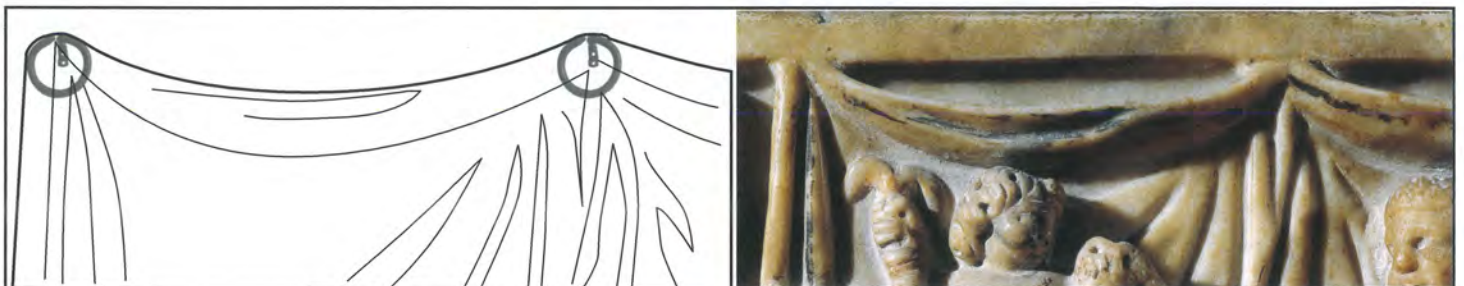



image 4

Image 5

Date 4th Century

Title Fresco from the interior of a Via Latina Catacomb (fresco)

Creator Roman, (4th century AD)

Description The panel depicts the story told in Judges 15:14-17 of the battle between Samson and the Philistines, in which Samson kills a thousand men with the jawbone of a donkey

Location Catacomb of Via Latina, Rome, Italy

Medium fresco

Period Hardware The Antique Drapery Rod Company Inc., Glossary page 57

Period Textiles Possibly hand woven linen or Indian cotton.

Period Music Synaulia, Music from Ancient Rome - Volume 2 String Instruments

Music Link Cithara and Sambuca

<https://itunes.apple.com/us/album/music-from-ancient-rome-vol/id91042805>

Notes: Notice the draped windows and open doorway in the style of the time. This may have been an entirely “draped room” or “antique draping.” Archeological remains show dwellings with no doors and infer a similar interior draped door. The iron works of this time also show iron rods with forged pegs from which the drapery would hang.

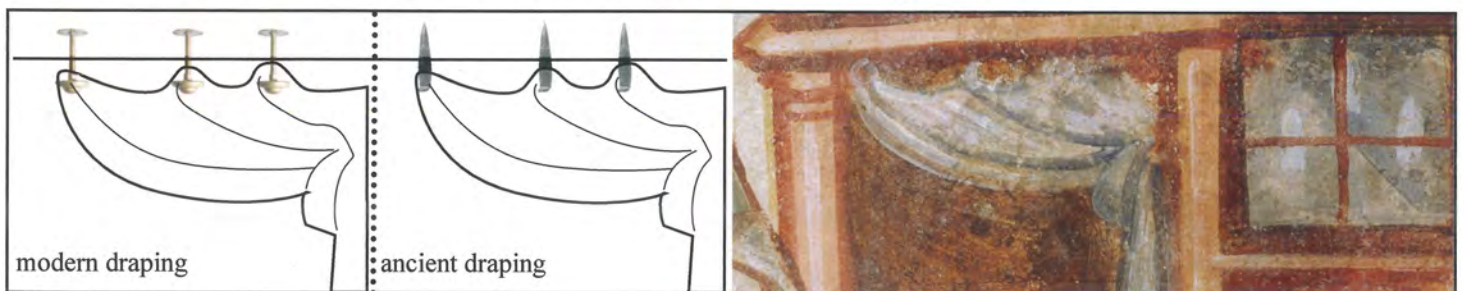



image 5

Image 6

Date 6th Century, 500 AD

Title Relief carving of an Empress, c.500 AD (ivory)

Creator Byzantine School, (6th century)

Location Museo Nazionale del Bargello, Florence, Italy

Medium ivory

Period Hardware The Antique Drapery Rod Company Inc., Glossary page 57

Period Textiles Hand woven Byzantine silk.

Period Music Costas Zorbas, Byzantine Music of the Greek Orthodox Church - The Akathist Hymn B' Ave Maria

Music Link 3rd Stanza (N-S)

<https://itunes.apple.com/us/album/volume-7-akathist-hymn-b-ave/id281857389>

Notes Our “Empress of Drapery Rods”; Empress Theodora was “Empress Regent” co-regent in her own right (525 to 548) with her co-regent Emperor Justinian of the Byzantine Empire where she was considered to have engineered the survival of the reign when threatened by riots. She and her husband’s many accomplishments include rebuilding Constantinople and building the Hagia Sophia (537 to 1453), the largest Christian Church in the world for over 900 years. In most images of the Empress Theodora there is a draped doorway or wall. In this image there is a draped rod behind her and she is holding a scepter, very similar to a drapery rod. We have made hand cast finials the “Empress Theodora” in both 2” and 1” scale to match.

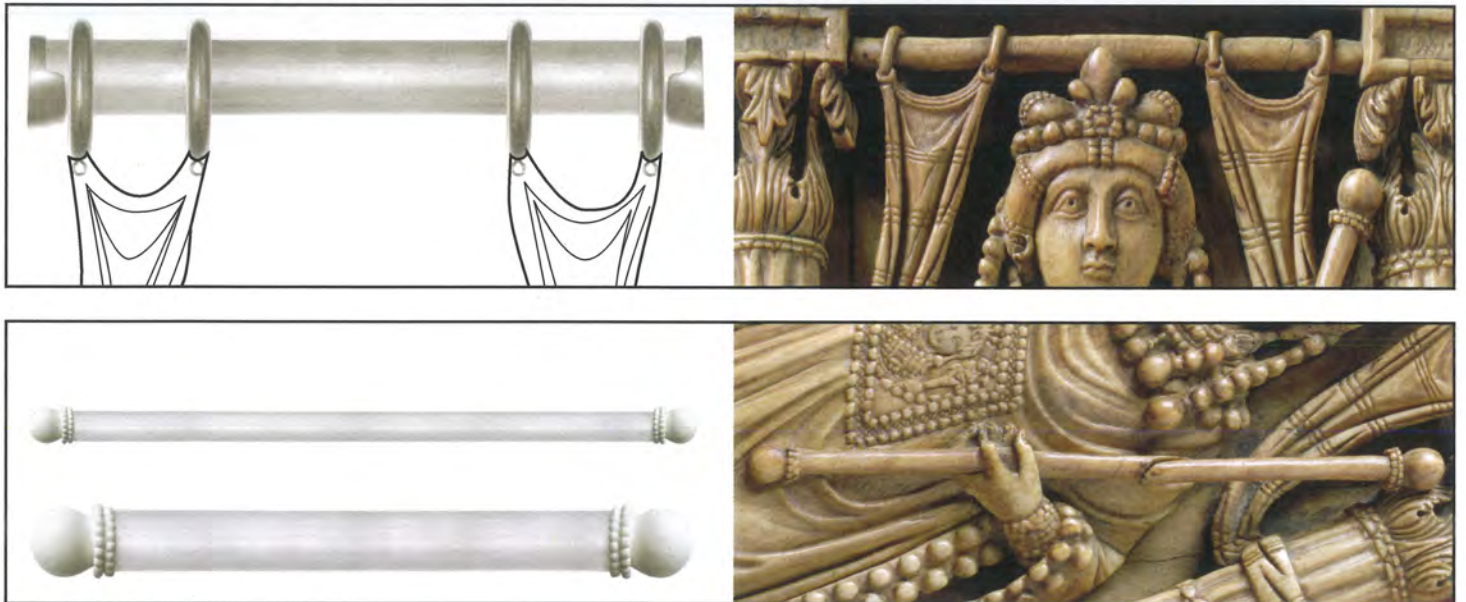



image 6

Image 7

Date 6th Century, 547 AD

Title Empress Theodora with her court of two ministers and seven women, c.547 AD (mosaic)

Creator Byzantine School, (6th century)

Description Theodora, empress from 527 -548 AD, wife of Justinian I (483-565);

Location San Vitale, Ravenna, Italy

Medium mosaic

Period Hardware The Antique Drapery Rod Company Inc., Glossary page 58

Period Textiles Hand woven Byzantine silk.

Period Music Costas Zorbas, Byzantine Music of the Greek Orthodox Church - The Akathist Hymn B' Ave Maria

Music Link 4th Stanza (T-Z)

<https://itunes.apple.com/us/album/volume-7-akathist-hymn-b-ave/id281857389>

Notes Empress Theodora with a draped doorway (left) and a draped hallway (at left). See also Image 6 Notes.





image 7

Image 8

Date 7th Century, 698 to 714 AD

Title Gospel of St. Matthew of the Lindisfarne Gospels

Medium parchment

Period Hardware The Antique Drapery Rod Company Inc., Glossary page 58

Period Textiles Dyed wool using woad (blue), weld (yellow) and madder (red).

Period Music Gregoria Chant Scola, Gregorian Chants of St. John's Abbey

Music Link Hymnis angelicis

<https://itunes.apple.com/us/album/singing-mary-saints/id722281831>

Notes Today you may visit the ruins of the medieval priory on “The Holy Isle of Lindisfarne” off the northern coast of England. The iron rod, ceiling brackets and rings could have been made by the monks of this priory. This style has been used consistently in the area for over 1300 years.

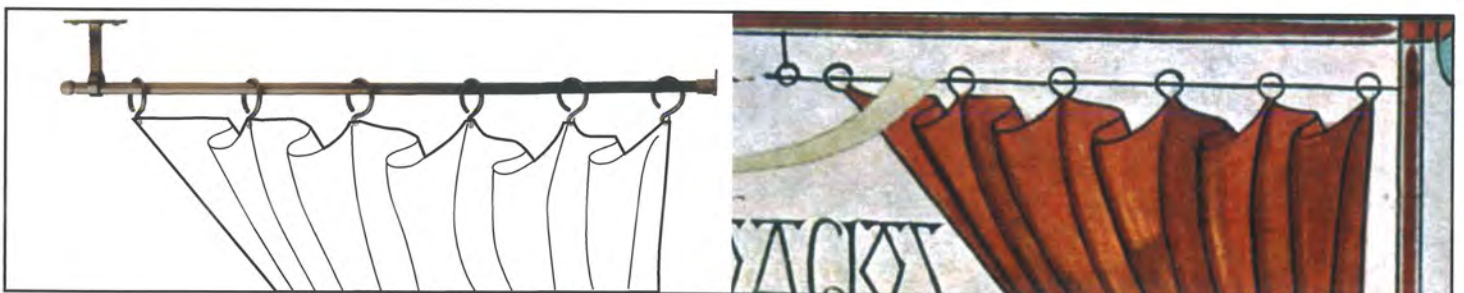



imago homi

nis :

ΣΑΚΚΟΥ

HALL

HEUS

Image 9

Date 7th Century

Title Constantine IV granting Bishop Reparatus privileges for the church of Ravenna, 671-77 (mosaic)

Description Tiberius, brother of Constantius Pogonatus (654-85) is on the left of the Emperor; Emperor from 668-85;

Creator Byzantine School, (6th century)

Location Sant'Apollinare in Classe, Ravenna, Italy

Medium mosaic

Period Hardware The Antique Drapery Rod Company Inc., Glossary page 58

Period Textiles Hand woven Byzantine silk.

Period Music Capella Romana, Music of Byzantium

Music Link Kanon in Honor of St Thomas Aquinas
<https://itunes.apple.com/us/album/music-of-byzantium/id278563699>

Notes Byzantine mosaic of a sumptuous interior with a long iron rod, draperies with a pinched pleat and decorated “loop top” instead of drapery rings. Most likely the rod was attached with a form of ceiling bracket. Artistic licence with gravity required. Also refer to Image 6.





CONSTANTINVS MAIOR IMPERATOR
HERACLI ET TIBERIC IMPERATOR

AR
TOP
YS

PRIVILEGIUM

1816 IANUARI 25 ANNO 1000 REPARATA VALESSET
AN ANNO 1000 IANUARI 25 ANNO 1000 REPARATA VALESSET

image 9

Image 10

Date 9th Century, 850 AD

Title St. Gregory writing with scribes below, Franco-German School, c.850-875 (ivory)

Creator Carolingian School (9th century)

Location Kunsthistorisches Museum, Vienna, Austria

Medium ivory

Period Hardware The Antique Drapery Rod Company Inc., Glossary page 59

Period Textiles Hand woven wool

Period Music Bernard Fabre, Missa Pange Lingua & Motets by J. Desprez

Music Link Plain - Chant: Pange lingua

<https://itunes.apple.com/us/album/j.-desprez-missa-pange-lingua/id815566421>

Notes Our notes here refer to the time period of the artists, 9th Century, 850 AD, Carolinian (Franco German). The artists scale infers the drapery rod shown may have been wooden or iron. The draperies are “loop tops”, extremely long and wrapped around the pillars to dramatic effect, “framing” St. Gregory with drapery, adding shadow and depth to the mysteries of his work.

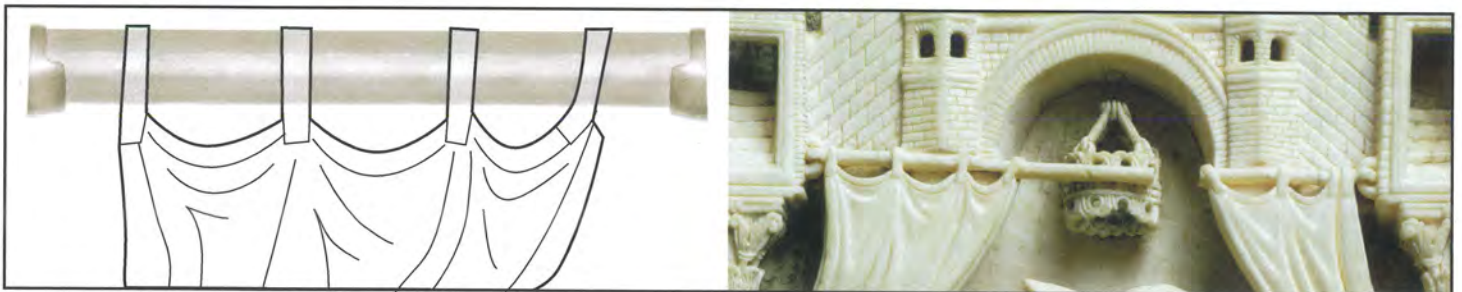



image 10

Image 11

Date 10th Century, 982 - 983 AD

Title The Crowning of Otto II (955-983) and Theophrano (958-991) from a plaque binding, c.982-983 (ivory)

Creator Byzantine, (10th century)

Description Plaque representant le Christ couronnant Othon et Theophano; figure on bottom left is the donor, John Philagathos, Bishop of Plaisance;

Location Musee National du Moyen Age et des Thermes de Cluny, Paris

Medium ivory

Dimensions 18x10 cms

Period Hardware The Antique Drapery Rod Company Inc., Glossary page 59

Period Textiles Hand woven Byzantine silk.

Period Music Costas Zorbas, Byzantine Music of the Greek Orthodox Church, Hymn of the Vespers. Volume 1

Music Link Ascending and 2 choir Hymns
<https://itunes.apple.com/us/album/volume-1-hymns-vespers-matins/id281857202>

Notes This draped coronation arch would have iron nails or decorated medallions with famous Byzantine silk drapery panels. Notice the light feel of the draping with this artist's hand as opposed to the heavier draping of Christ's robes and the weighted adornment of Emperor Otto II and Empress Regent Theophrano.

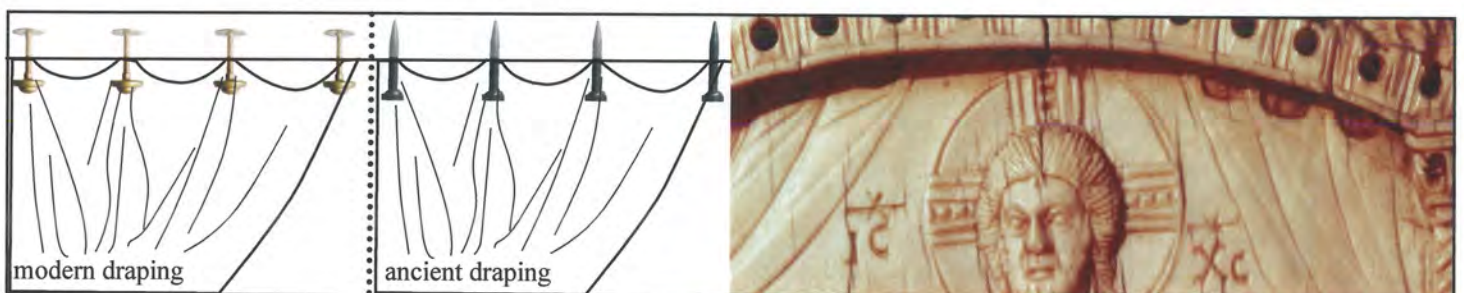



image 11

Image 12

Date 12th Century

Title The Ecstasy of St. Gregory (c.540-604) glimpsed by the Deacon Peter through a curtain pierced by his stilet

Creator Flemish School, (12th century)

Nationality Flemish

Description extase de Saint Gregoire apercu par le diacre Pierre a travers le rideau perce de son stilet; dove perching on his shoulder; suggestion of the divine inspiration of his writings; Father of the Latin Church

Location Bibliotheque Royale de Belgique, Brussels, Belgium

Medium vellum (b/w photo)

Period Hardware The Antique Drapery Rod Company Inc., Glossary page 59

Period Textiles English wool woven in Flanders

Period Music Anonymous 4, Hildegard von Bingen: 11,000 Virgins

Music Link Benedicamus domino

<https://itunes.apple.com/us/album/hildegard-von-bingen-11-000/id586077828>

Notes The draped archway shown here with thick curtains tied into a dramatic division between the divine (St. Gregory) and the earthly (Deacon Peter). Most likely attached with loops to a stone archway with iron nails or pegs.

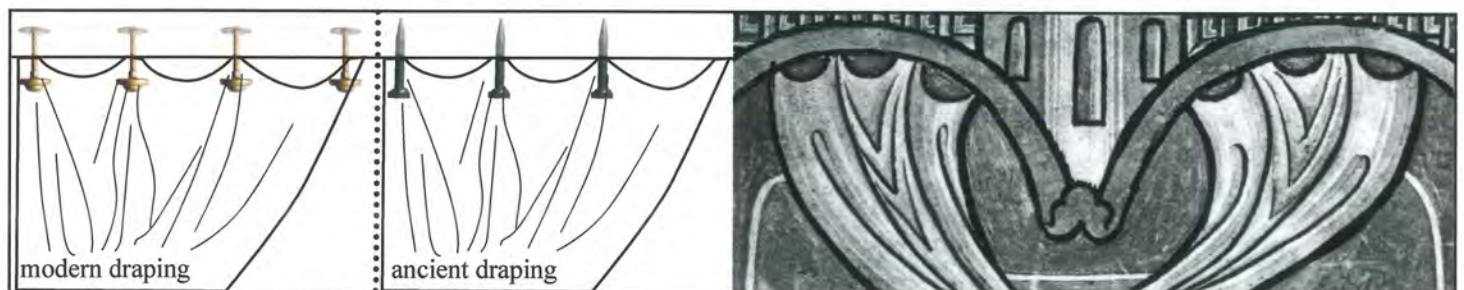



image 12

Image 13

Date 14th Century

Title Ms 137/1687 fol.87v The Extreme Unction (vellum)

Creator French School, (14th century)

Nationality French

Description Collection of Treatise on Devotion;

Location Musee Conde, Chantilly, France

Medium Vellum

Period Hardware The Antique Drapery Rod Company Inc., Glossary page 60

Period Textiles Hand woven silk or linen.

Period Music Hillard Anseble, Guillaume de Machaut: Motets

Music Link De Souspirant Cuer, M2
<https://itunes.apple.com/us/album/guillaume-de-machaut-motets/id110430756>

Notes We do not know if the hardware in this 14th Century image was hinged. However, similar treatments in iron for the past several hundred years have been hinged. These are referred to as “French swing arms” and open into a room usually in front of wood or glass windows or doors. The tie backs were most likely carved wood and kept textiles from moving with the wind, and in this case, forming a graceful frame for the subjects of the painting.





I au filz le
Sacremēt

donnez a home apres to
les autres sacremens .

Image 14

Date 14th Century, 1357-1364

Title Stories of Virgin Mary (Storie della Vergine), by Ugolino from Prete Ilario, 1357 - 1364, 14th Century, fresco

Description Whole artwork view. In the central part of the work the announcement of the angel to Joseph and Mary.

Location Duomo, Orvieto, Umbria, Italy

Medium fresco

Period Hardware The Antique Drapery Rod Company Inc., Glossary page 60

Period Textiles Hand woven silk with hand embroidered border at top.

Period Music L'Homme Arme & Fabio Lombardo, Regina Pretiosa: Una Celebrazione Mariana del Trecento Firointino

Music Link Regina Pretiosa

<https://itunes.apple.com/us/album/regina-pretiosa-una-celebrazione/id652526136>

Notes Iron rods connecting archways or columns were often architectural supports. When these iron rods were hung with draperies or textiles, they also were space dividers forming rooms for receiving, working or in this case, sleeping. Notice the bed behind the Madonna. The magnification indicates these textile panels were hung with iron rings forming a highly decorative private space.

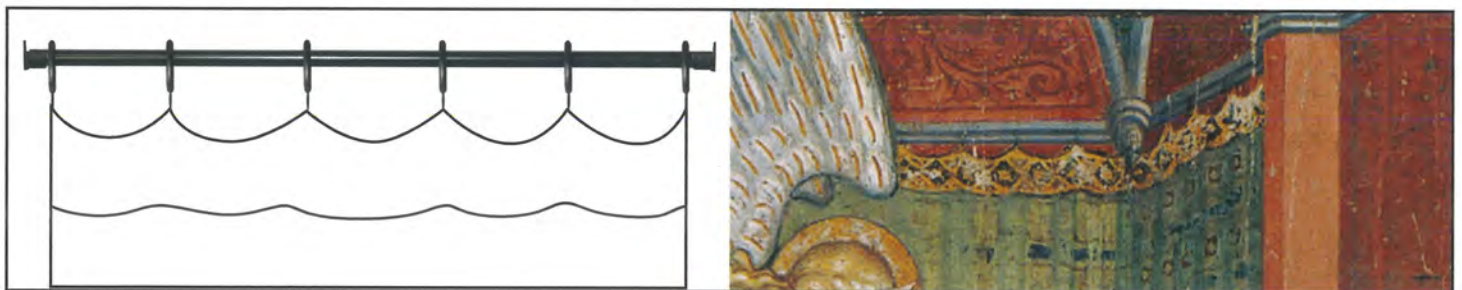



Image 15

Date 14th Century

Title Ms 277/1327 Nicolas Oresme (c.1320-82) presents his work to Charles V (1338-80) and Human Happiness, from 'The Ethics' by Aristotle (384-322 BC) (vellum)

Creator French School, (14th century)

Nationality French

Description Nicolas Oresme offre son livre a Charles V;

Location Musee Conde, Chantilly, France

Medium vellum

Period Hardware The Antique Drapery Rod Company Inc., Glossary page 60

Period Textiles Hand woven silk or linen.

Period Music Alba Musica Kyo, Marchaut and His Time: 14th Century French Ars Nova

Music Link Doulz Viaire Gracieus
<https://itunes.apple.com/us/album/marchaut-his-time-14th-century/id270321961>

Notes Another French swing arm treatment (refer to Image 13). The draperies frame his beloved wife, Queen Joanna of Bourbon.

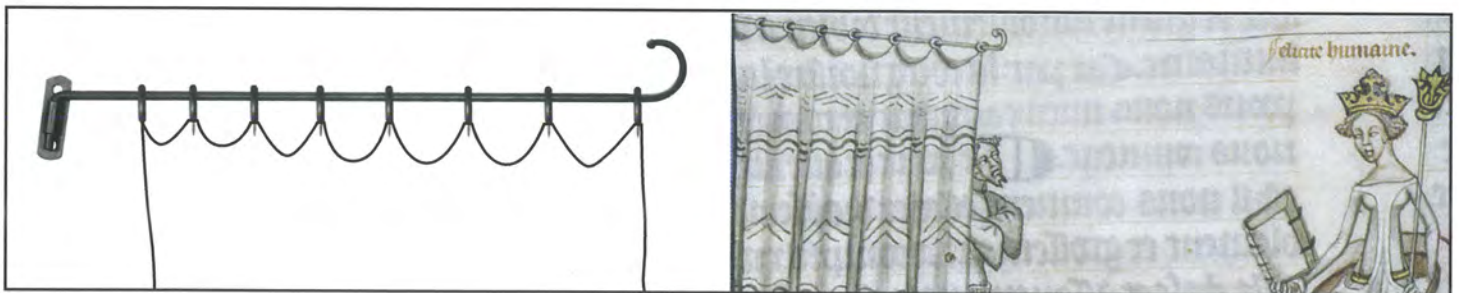



Tout art et toute doctrine **glose.** ilz entendent par art science pratique et par doctrine science speculative. et semblablement tout fait ou operation et election appetent et desirent aucun bien pour ce parloient bien les anciens endisant ainsi bien ce que toutes choses desirent. **glose** par de sur naturel come leur fin et leur perfection. et aucune fois desirer un homme mal mais cest pour ce que il ya aucune apparence de bien. **nexte** Et semble que il est difference de fins Car les vnes fins sont les operations **glose** comme chanter ou dancier **nexte** les autres sont aucunes ceu

unes **glose** comme vne maison ou un vaissel **nexte.** ou choses faites lors les operations ou facons et ces oeuvres sont meilleurs que les operations pour quoy ilz sont faites. **C**est come il soit moult d'operations et d'arts et de doctrines pour ce est il moult de fins si come de medicine la fin est sante de faire nauue la fin est aller par jaue et en nagant de deualer la fin est vitour. et iceles sont la fin de yconomie. **glose.** yconomie est art de gouverner un hostel et les appartenances pour acquerir iceles et ceste fin est pour autre fin. c'est a sauoir pour bien user de celles. **glose.** Et de telles arts et doctrines aucunes sont desoubz vne autre si comme art de faire frans est soubz art de deuaucher.

Image 16

Date 15th Century, 1440

Title The Miracle of the Deacon Justinian, from the predella of the San Marco altarpiece, 1440 (tempera on panel)

Creator Angelico, Fra (Guido di Pietro) (c.1387-1455)

Nationality Italian

Description miracle de la greffe d'une jambe de Noir au diacre Justinien;

Location Museo di San Marco dell' Angelico, Florence, Italy

Medium tempera on panel

Dimensions 37x45 cms

Period Hardware The Antique Drapery Rod Company Inc., Glossary page 61

Period Textiles Hand cut Italian velvet

Period Music Francis Biggi, Ars italica, Musica del XV Secolo in Italia by Marco Ferrari, Sigrid Lee, Francis Biggi and Ars Italica

Music Link Rostiboli Gioioso
<https://itunes.apple.com/ie/album/musica-del-xv-secolo-in-italia/id666844859>

Notes This drapery as a room divider in contemporary use could be a 21st Century loft with a platform bed in New York or London. The rod and rings of the third wall of drapery (foot of bed) are hidden by the folds of the front panels, leaving space for a walkway in front of the raised bed. Note the fullness and weight of the velvet draperies which were woven in Florence and Venice in the 15th Century.

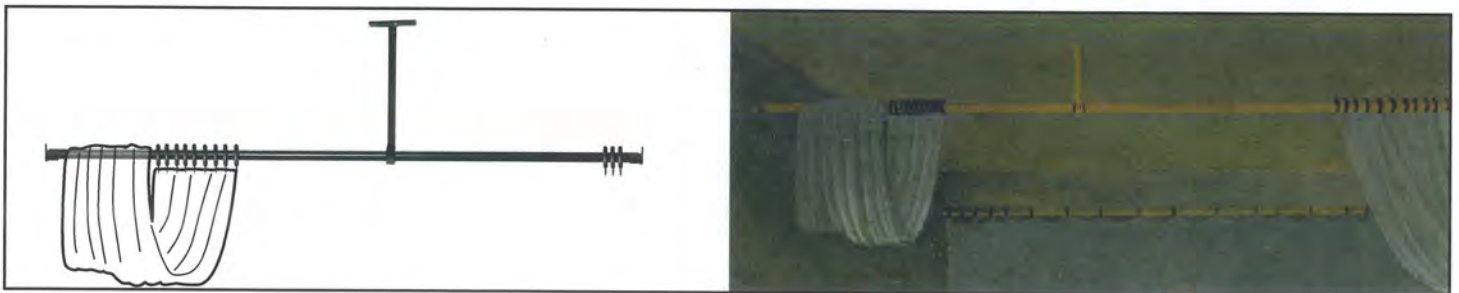



image 16

Image 17

Date 15th Century, 1488

Title Barbarigo Altarpiece (Pala Barbarigo), by Giovanni Bellini, 1488, 15th Century, canvas, 205 x 334 cm

Creator Bellini, Giovanni (c.1430-1516)

Nationality Italian

Description Whole artwork view. The painting represents the Madonna and Child, St. Augustin (on the left with a bishop's uniform), the kneeling Doge Agostino Barbarigo (on the right) with Saint Mark, two musician angels and twelve puttoes.

Location Church of St. Peter Martyr, Murano, Veneto, Italy

Medium oil on canvas

Dimensions 205x334 cms

Period Hardware The Antique Drapery Rod Company Inc., Glossary page 61

Period Textiles Hand cut Italian velvet

Period Music Francis Biggi, Ars italica, Musica del XV Secolo in Italia by Marco Ferrari, Sigrid Lee, Francis Biggi and Ars Italica

Music Link Salve, virgo regia

<https://itunes.apple.com/ie/album/musica-del-xv-secolo-in-italia/id666844859>

Notes Embroidered red velvet draperies gently folded over a rod as a backdrop. The center portion of the draperies open to a room behind the madonna and child with an embroidered (or carved wood) architectural pediment and contrasting green walls.

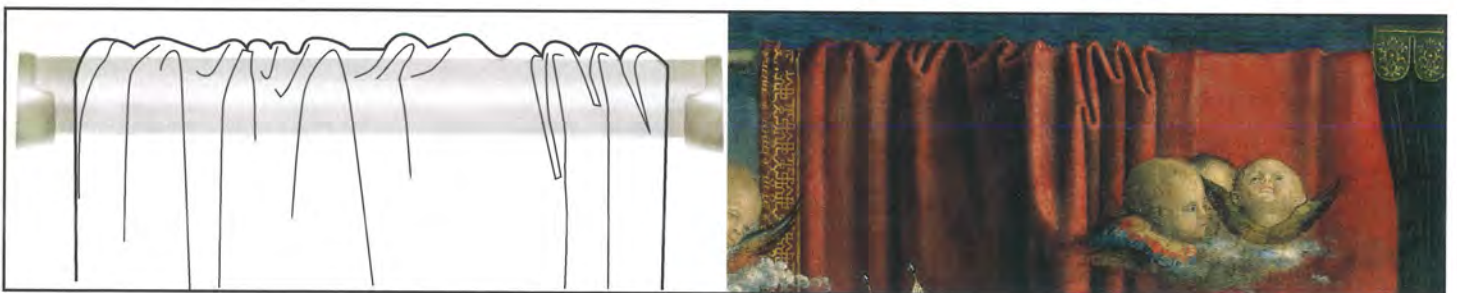

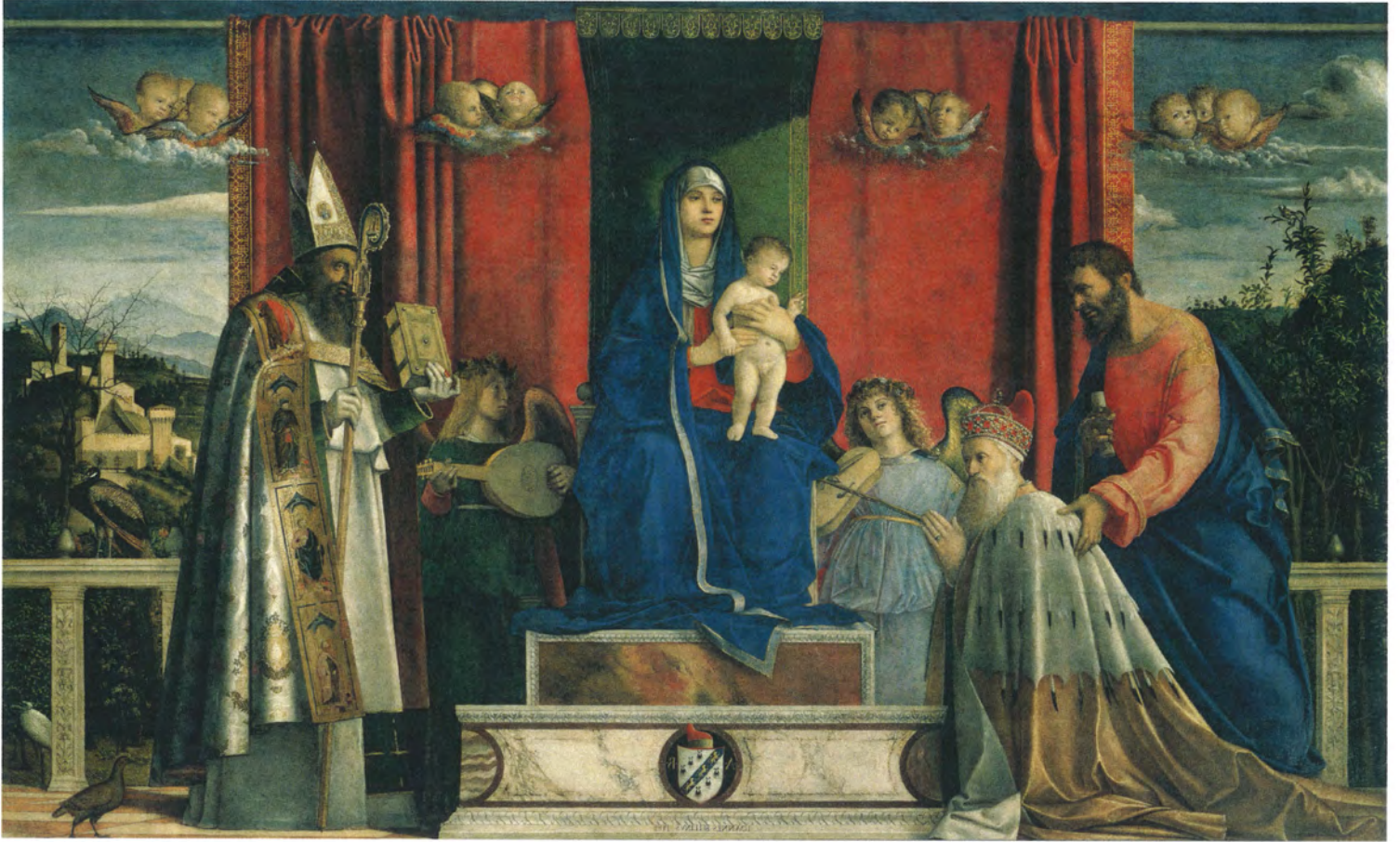

image 17

Image 18

Date 16th Century, 1523

Title Portrait of Erasmus

Creator Holbein the Younger, Hans (1497/8-1543)

Nationality German

Description Desiderius Erasmus (1466-1536); humanist scholar and philosopher; on loan to the National Gallery, London from the collection of the Earl of Radnor

Location Private Collection

Medium oil and egg tempera on panel

Dimensions 74.5x52.5 cms

Period Hardware The Antique Drapery Rod Company Inc., Glossary page 61

Period Textiles Hand woven Velvet

Period Music Charles Daniels & Fretwork, Ludwig Senfl

Music Link Im Maien

<https://itunes.apple.com/us/album/ludwig-senfl-im-maien/id586114456>

Notes A classic black iron rod and black iron rings. Draperies in the piece as a room divider between a working space and a more formal space. Note the inconsistent spacing of rings and a feeling the drapery could have been recently, casually partially closed.

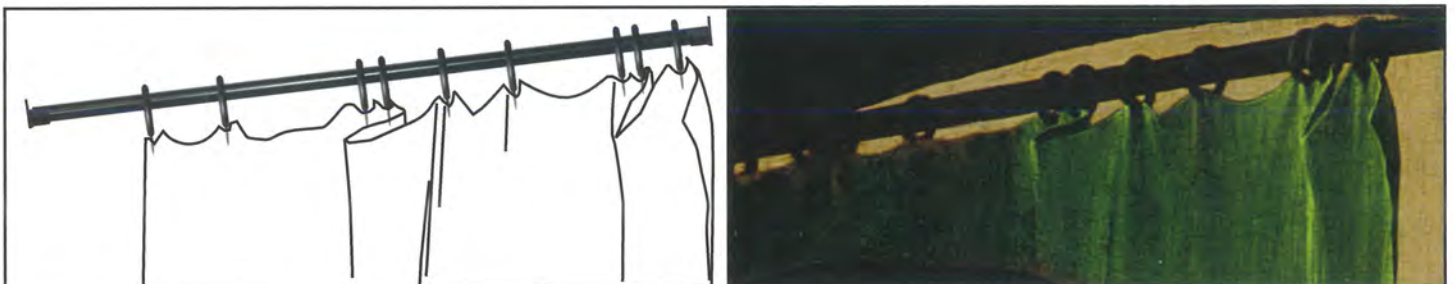



image 18

Image 19

Date 16th Century, 1550

Title Visitation, Birth and Circumcision of St John, 1550

Creator Italian School, (16th century)

Nationality Italian

Description Detail. Classical building columns gable, frieze, a woman in labor. St Elizabeth midwife handmaids bed raised curtains new-born baby St John the Baptist birth garden tree branches tapestry frame

Location Basilica di San Giovanni Battista, Monza, Italy

Period Hardware The Antique Drapery Rod Company Inc., Glossary page 62

Period Textiles Hand woven velvet or wool.

Period Music Markus Tapio, Barzelleto - North Italian Frottole of the Early 16th Century

Music Link Recerchar secondo (for Viola da Gamba)
<https://itunes.apple.com/us/album/barzelleto-north-italian/id815633965>

Notes We have included this piece as an excellent example for a garden folly, gazebo or patio treatment. Completely enclosed with draperies, it would be easier today to open and close the draperies with our c ring brackets and c rings.

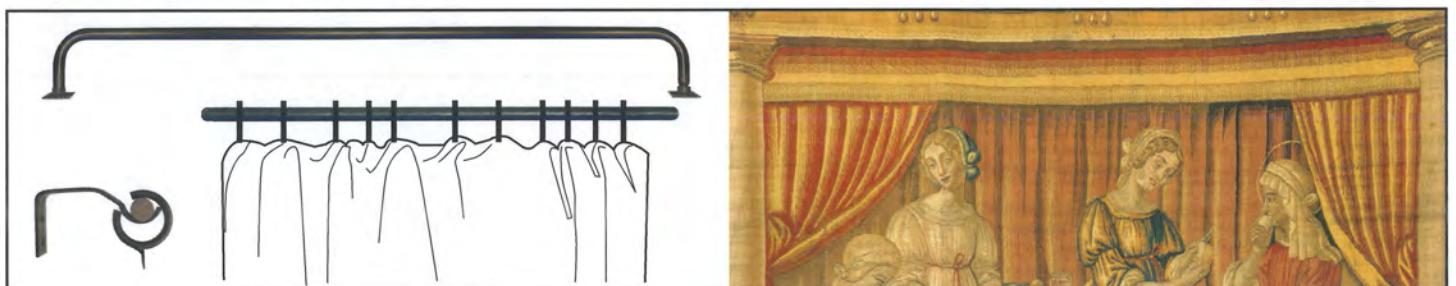



image 19

Image 20

Date 17th Century, 1646

Title Holy Family with a Curtain

Creator Rembrandt Harmensz. van Rijn (1606-69)

Nationality Dutch

Description the Holy Family with a framework and painted curtain

Location Gemaeldegalerie Alte Meister, Kassel, Germany

Medium oil on panel

Dimensions 46.8x68.4 cms

Period Hardware The Antique Drapery Rod Company Inc., Glossary page 62

Period Textiles Hand woven, hand cut velvet

Period Music Peter Ouwkerk, Rembrandt, music of his time

Music Link Tablatuur-boeck van pasalmen en fantasyen: Psalm XXIV
<https://itunes.apple.com/ca/album/art-music-rembrandt-music/id457799549>

Notes Although a similar draped room divider may have been in 17th Century homes, the placement of the drapery and rod in front of the architectural pediment places in the drapery as a symbol for the veil between the human and the divine.

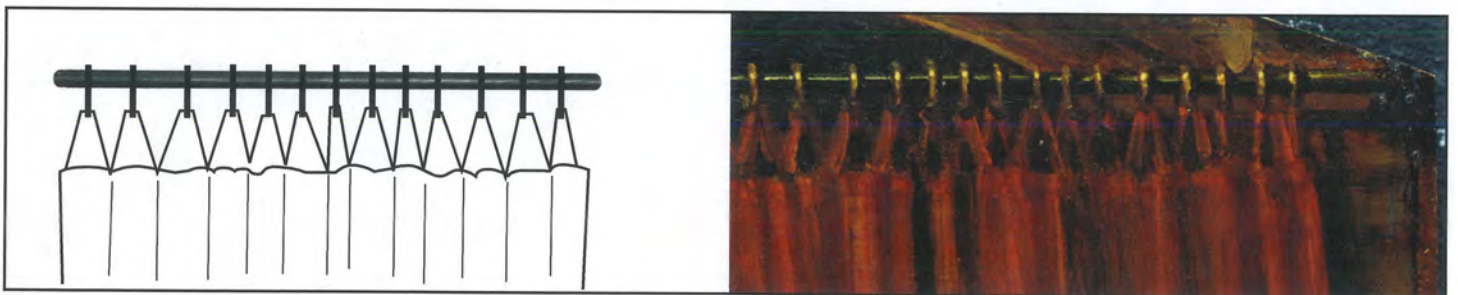



image 20

Image 21

Date 17th Century, 1632-1675

Title Girl at a Window Reading a Letter (oil on canvas)

Creator Vermeer, Jan (Johannes) (1632-75)

Nationality Dutch

Description Brieflesendes Madchen am offenen Fenster; La Liseuse a la fenetre

Location Gemaeldegalerie Alte Meister, Dresden, Germany

Medium oil on canvas

Dimensions 83x64.5 cms

Period Hardware The Antique Drapery Rod Company Inc., Glossary page 62

Period Textiles Hand woven silk

Period Music Camerata Trajectina, Huygens: Dutch Music in the 17th Century

Music Link Courante

<https://itunes.apple.com/us/album/huygens-dutch-music-in-17th/id263483188>

Notes Vermeer's use of light reflecting off the draperies at right brightened the mood of the painting. The room has a very high ceiling and a second window above the open window. The drapery panel at left stops at the bottom of the window sill. The room dividing drapery at right has a bottom hem with fringe touching the top of the bed or table and forming once again a screen between a private and public world.

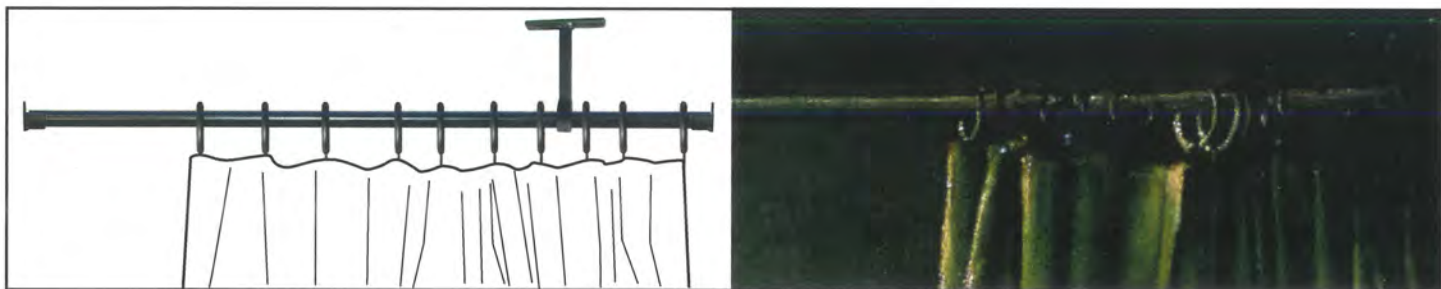



image 21

Image 22

Date 18th Century architecture, 1845; 19th Century engraving

Title Lansdown Tower - The Scarlet Drawing-Room, published in 'The Illustrated London News', 1845 (engraving)

Creator English School, (19th century)

Description Lansdown Tower (now known as Beckford's Tower) was a neo-classical folly built by William Beckford (1760-1844) on Lansdown Hill, Bath; There were two drawing rooms at the base of the tower, one scarlet and one crimson; They are said to have had rich carpets, luxurious curtains and coffered ceilings panelled in oak and enriched with scarlet, crimson, purple and gold;

Location Private Collection

Medium Engraving

Period Hardware The Antique Drapery Rod Company Inc., Glossary page 63

Period Textiles Hand loomed velvet.

Period Music Alfred Brendel, Mozart: Piano Concertos K.271

Music Link Jeunehomme

<https://itunes.apple.com/us/album/mozart-piano-concertos-k.271/id4673642>

Notes William Thomas Beckford was a famous art collector, novelist and politician. He briefly trained in music by Wolfgang Amadeus Mozart. Beckford wrote a considerable amount of music, much with the assistance of John Burton including "Arcadian Pastoral", (not currently available on iTunes). We have chosen Mozart's 1776 piano concerto which premiered during the time Beckford studied music.

Classic English forge works were very fashionable at the time of this engraving. The window at left shows a long thin rod above the side panels and above the curved window alcove.

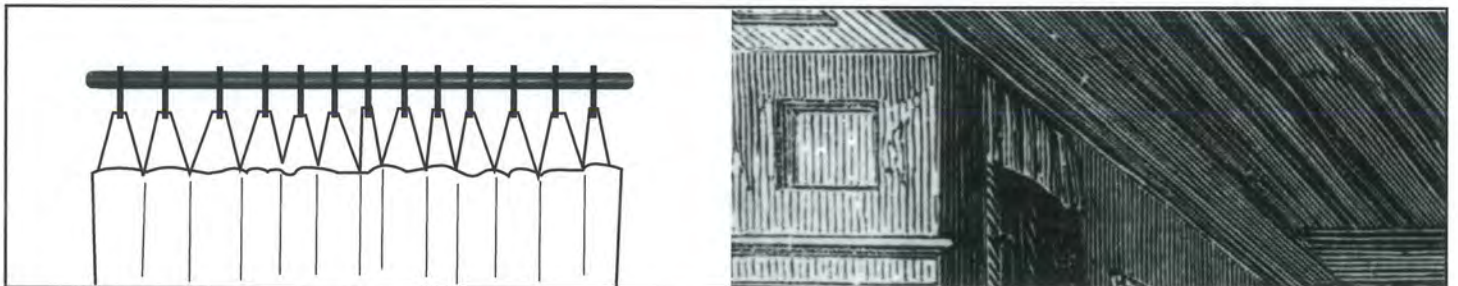

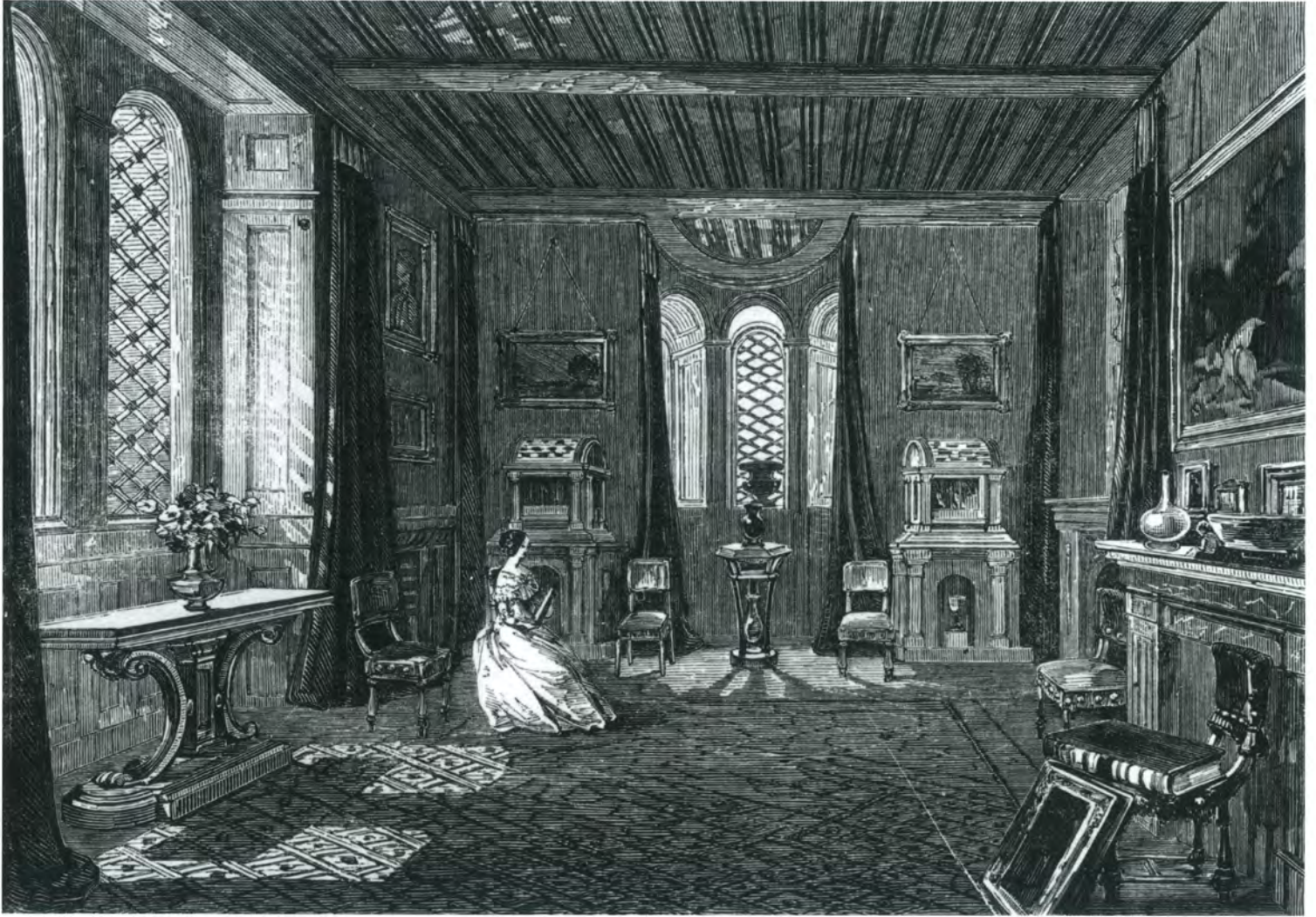

Image 23

Date 19th Century, 1834

Title Moresque Interior, from “Album of a Voyage to Spain, Morocco and Algeria”

Creator Ferdinand Victor Eugene Delacroix

Nationality French

Location Mussee Conde, Chantilly, France

Medium watercolor on paper

Period Hardware The Antique Drapery Rod Company Inc., Glossary page 63

Period Textiles Hand woven cotton

Period Music Various artists, Morocco (Sounds from an Ancient Land)

Music Link Gullu Bent Halima

<https://itunes.apple.com/us/album/morocco-sounds-from-ancient/id83065315>

Notes Delacroix traveled to Spain and North Africa as part of a diplomatic mission to Morocco shortly after the French captured Algeria. Delacroix was enthralled with the people, costumes and culture. We have chosen music he could have easily experienced during his travels there. Morocco’s iron work has been famous for centuries for its intricate iron windows, iron gate, lamps and accessories. The iron “radius” rod allows space for the drapery to hang over the door when it is closed or shield the opening from the sun when it is open. You may see versions of the treatment today in Morocco.





image 22

Image 24

Date 19th Century, 1880

Title Reading by the Window, Hastings, 1880 ()

Creator Lewis, Charles James (1830-92)

Description Reading by the Window, Hastings. Charles James Lewis (1830-1892). Dated 1880.

Location Private Collection

Medium Oil on card

Dimensions 26.7x35 . cms

Period Hardware The Antique Drapery Rod Company Inc., Glossary page 63

Period Textiles Organdy or voile

Period Music Joan Sutherland La Stupenda - Joan Sutherland, John Field

Music Link The Boheimium Girl

<https://itunes.apple.com/ie/album/la-stupenda-supreme-joan-sutherland/id116981753>

Notes A fitting end to our images. The thin line of the classic iron rod attached to the wood trim of the bay window. the light fabric moving in a spring breeze. These draperies are strictly decorative, yet essential to the atmosphere of the room. Imagine the room without the draperies, one half greenhouse and much less well finished.

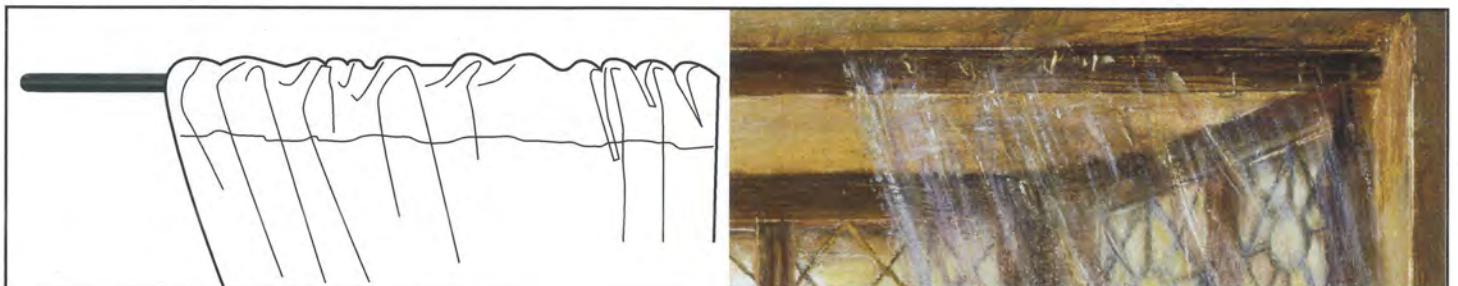



image 24

Top Image

Date Early iron age tools

Title France, Vertillum, Instruments used for iron work hammer and nails

Description France, Burgundy, Chatillon Sur Seine, Burgundy, Chatillon Sur Seine, Musee Du Chatillonnais (Archaeological Museum), Gallo-Roman civilization

Location Chatillon Sur Seine, Musée Du Châtillonnais (Archaeological Museum)

Bottom Image

Date Early iron age tools

Title France, Vertillum, Instruments used for iron work pliers and chisel

Description France, Burgundy, Chatillon Sur Seine, Musee Du Chatillonnais (Archaeological Museum), Gallo-Roman civilization

Location Chatillon Sur Seine, Musée Du Châtillonnais (Archaeological Museum)

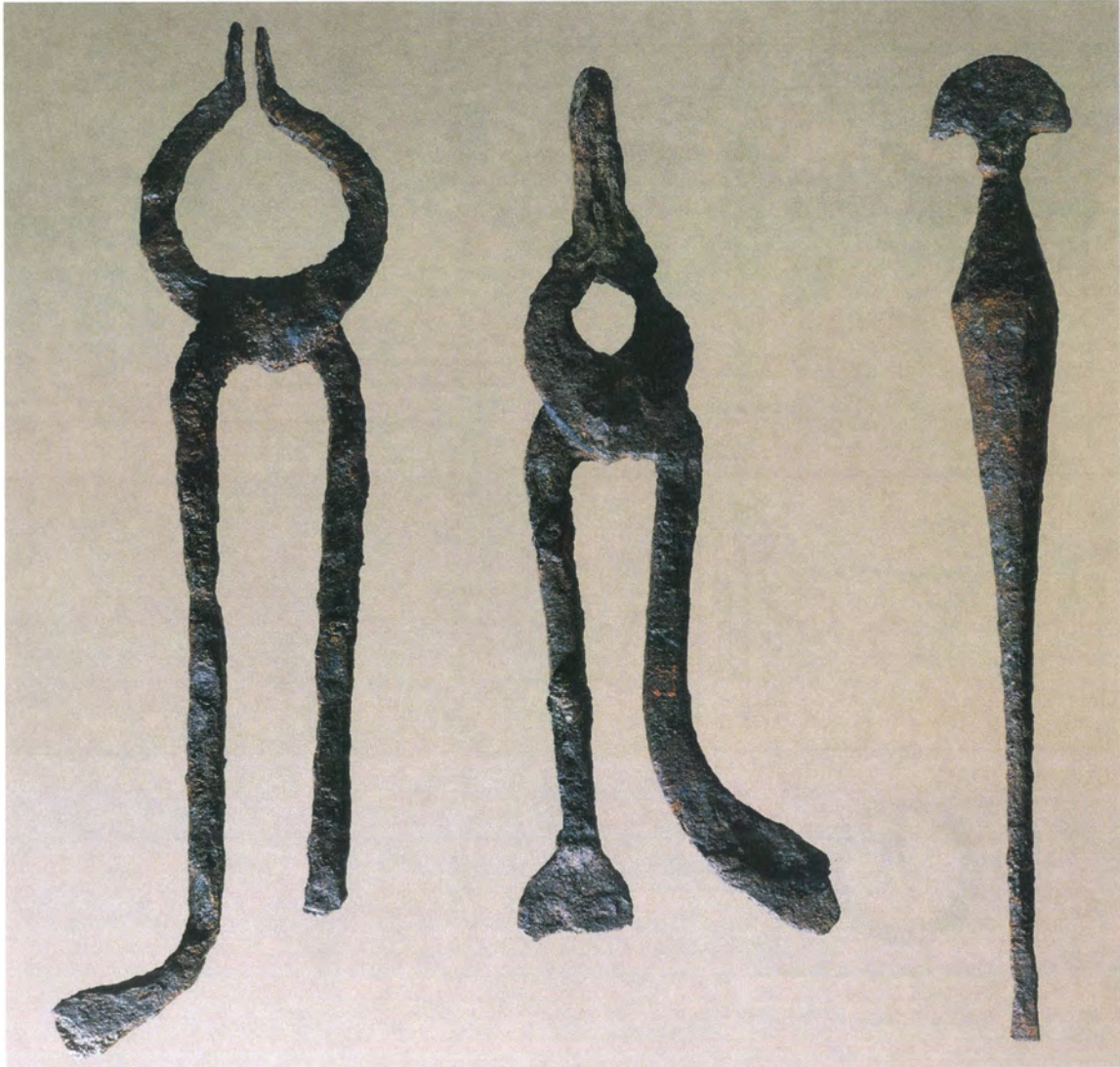
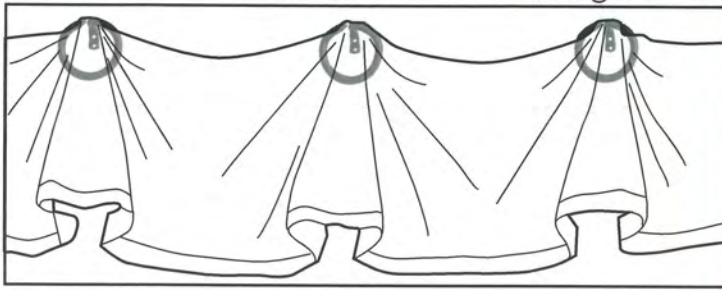

image 1 - iron ring swag



Small Ring Swag Brkt
BR_NRB, single;
4" DIA X 2" DEEP



Large Ring Swag Brkt
BR_LRB, single;
6" DIA X 2" DEEP

image 2 - ceiling brackets and rod

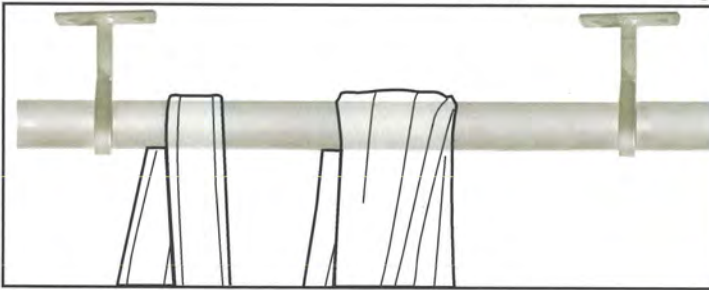

5/8" Round Solid Rod

| | | | |
|--|------------|------------|---|
| Ceiling Tube Brkt® BR_CT1, pair Rtn: 3 1/4" 1" w X 3 1/4" h X 3 1/8" l | 12" RR_10R | 48" RR_40R | 84" RR_70R |
| | 18" RR_16R | 54" RR_46R | 90" RR_76R |
| | 24" RR_20R | 60" RR_50R | 96" RR_80R |
| | 30" RR_26R | 66" RR_56R | 102" RR_86R |
| | 36" RR_30R | 72" RR_60R | Custom Cut for rods under 8'6" CUT FEE |
| | 42" RR_36R | 78" RR_66R | Available up to 39 feet |



| | |
|--|---|
| Ceiling Tube Bracket® BR_CTEA, pair Rtn: 3"; 2 1/2" w X 3 1/4" h X 4" l May also be used as wall mount. "Mullion base": attach to a stud, ceiling rafter or professionally install. | 1 3/4" Smooth Wood Rod® |
| | 12" RO_21W |
| | 24" RO_22W |
| | 36" RO_23W |
| | 48" RO_24W |
| | 72" RO_26W |
| | 96" RO_28W |
| | Custom Cut for rods under 8'6" CUT FEE extra long 1 3/4" Smooth Wood Rods over 8' RO_2CW per foot |

image 3 - iron ring swag

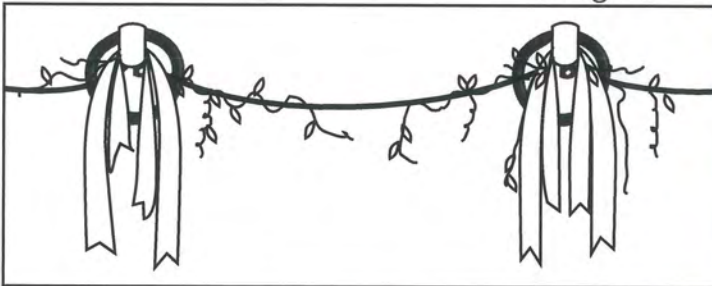

Small Ring Swag Bracket
BR_NRB, single;
4" DIA X 2" DEEP



Large Ring Swag Bracket
BR_LRB, single;
6" DIA X 2" DEEP

image 4 - iron ring swag

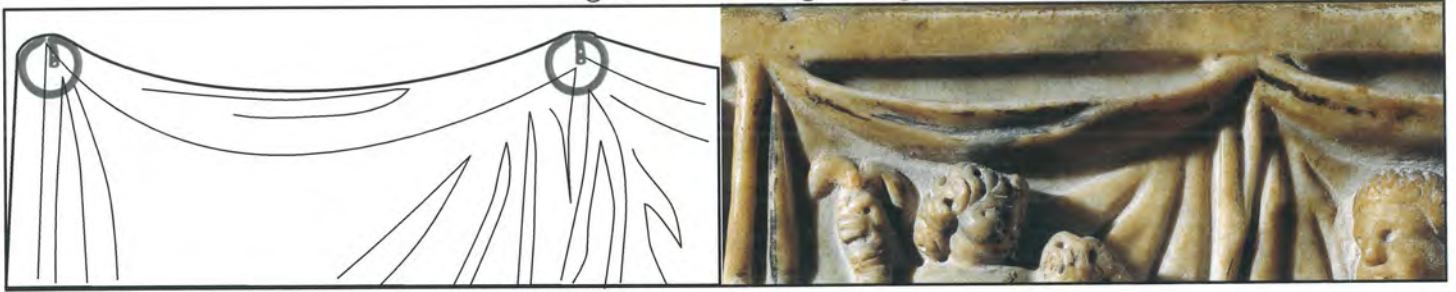

Small Ring Swag Bracket
BR_NRB, single;
4"DIA X 2" DEEP



Large Ring Swag Bracket
BR_LRB, single;
6"DIA X 2" DEEP

image 5 - iron nail with hand forged tiebacks

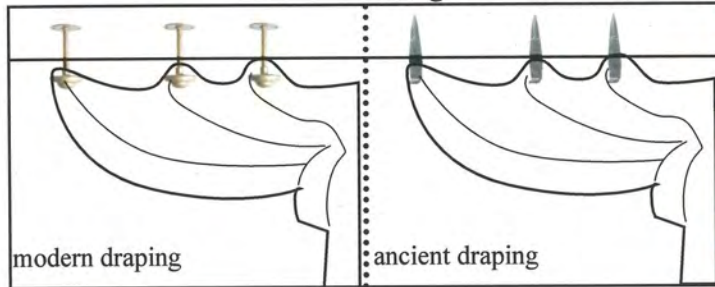

Twisted Hand Forged Simple Hook®
Round BR_TSP, single; 5" long; 1 1/8 x 1/2" HEAD
EXTRUDES FROM WALL APPROX. 3 1/2"



Serenity 2®
BR_S2W, pair
Rtn: 2 1/2"; 2 1/2" DIA X 1"L



Hand Forged Nail® Round BR_HFN,
single; 3 1/4" long; 7/8" HEAD DIAM
EXTRUDES FROM WALL APPROX. 2"



Venetian Tieback®
Round BR_VON, pair
Twisted BR_VEN, pair
Rtn 3", 9"w x 4 1/2" DEEP
Has 1" clearance for molding.
May add 1" finials to end.



Hand Forged Nail® Screw BR_HFS
single; 7/8" HEAD DIAM
EXTRUDES FROM WALL APPROX. 1"

image 6 - cafe brackets, rods and rings

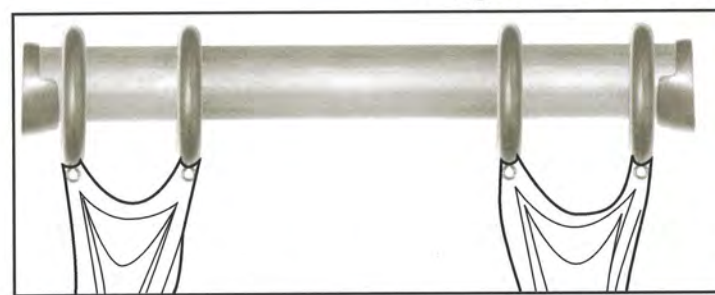

Cafe/Shower Bracket®
BR_CAW, pair;
Rtn: 7/8"
2 1/2"w X 2 1/2"h X 1"L



3" Ring
RI_17W, 7 Pk
RI_BNW, 50 Box
3 1/4" OD, 2 1/4" ID



1 3/4" Smooth Wood Rod®
12" RO_21W 48" RO_24W
24" RO_22W 72" RO_26W
36" RO_23W 96" RO_28W

Custom Cut for rods under 86"
CUT FEE
extra long 1 3/4" Smooth Wood
Rods over 8" RO_2CW per foot

image 6 - Empress Theodora's Scepter



2" Empress Theodora Finial®
FL_THD, pair; Base: 2" DIA
2 3/8"w X 2 3/8"h X 2 5/8"L



1" Empress Theodora Finial®
FL_TH1, pair; Base: 1" DIA
1 1/4"w X 1 1/4"h X 1 3/8"L



image 7 - hand forged nails and ring brackets



Hand Forged Nail® Round BR_HFN,
single; 3 1/4" long; 7/8" HEAD DIAM
EXTRUDES FROM WALL APPROX. 2"



Hand Forged Nail® Screw BR_HFS
single; 7/8" HEAD DIAM
EXTRUDES FROM WALL APPROX. 1"



Serenity 2® Medallion
BR_S2W, pair
Rtn: 2 1/2"; 2 1/2" DIA X 1"L

image 8 - hand forged Lindisfarne abby collection

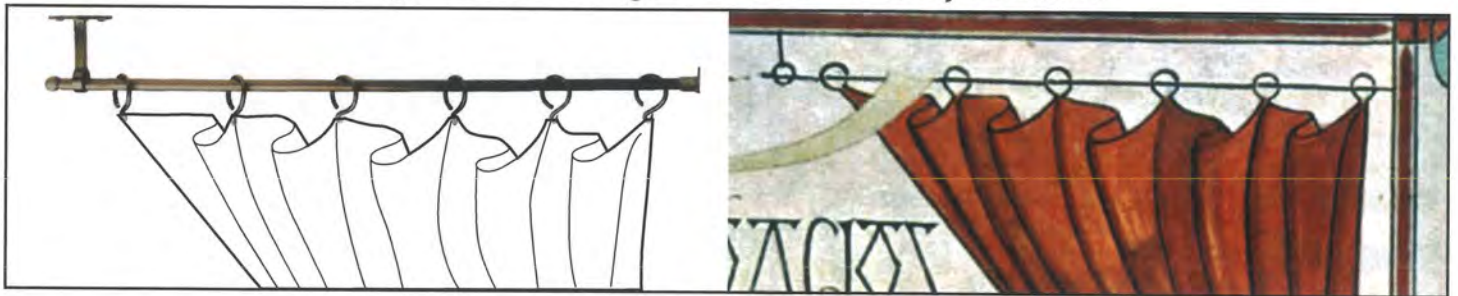

a)



b)



c)



d)



e)

ROD 4' Round Solid Rod, RR_40R
FINIAL Small Ball® FI_SMB, pair; 3/4"w X 3/4"h X 3/4"L
RINGS Hand Forged Iron Ring, RI_27F, 7 Pk; RI_25F, 50 Box
BRACKETS

- a) Ceiling Tube Bracket®; BR_CT1, pair; Rtn 3 1/4";
1"w X 3 1/4"h X 3 1/8"L
- b) 1" Kelly Bracket®; BR_KEL; pair; Rtn 3 1/4";
Base 1 7/8"w X 1 1/2"h; 1 1/2"w X 1 3/4"h X 3 3/4"L
- c) Tube Towel 3®; BR_TTS, pair; Rtn 3 1/4"; 2"w X 2 5/8"h X 4"L
- d) 1" Classic Iron®; BR_CLL, pair; Rtn 3 1/4"; Base 2 1/8" DIA.
- e) Stone Base Bracket, BR_LFG, pair; Rtn 3 1/4"

image 9 - iron rod, bracket and finials



5/8" Round Solid Rod

| | | |
|------------|------------|---------------------------------------|
| 12" RR_10R | 48" RR_40R | 84" RR_70R |
| 18" RR_16R | 54" RR_46R | 90" RR_76R |
| 24" RR_20R | 60" RR_50R | 96" RR_80R |
| 30" RR_26R | 66" RR_56R | 102" RR_86R |
| 36" RR_30R | 72" RR_60R | Custom Cut for rods under 86" CUT FEE |
| 42" RR_36R | 78" RR_66R | Available up to 39 feet |



Ceiling Bracket® (shown)
BR_CEI, pair
Rtn: 1 1/2"
3 1/4" w X 1" h



1" Tribeca Bracket®
BR_JK1; pair; Rtn 1 3/8";
Base 1 7/8"w X 1 1/2"h;
1 1/2"w X 1 7/8"h X 1 15/16"L
May be ceiling or wall mount

image 10 - cafe brackets, rods and rings

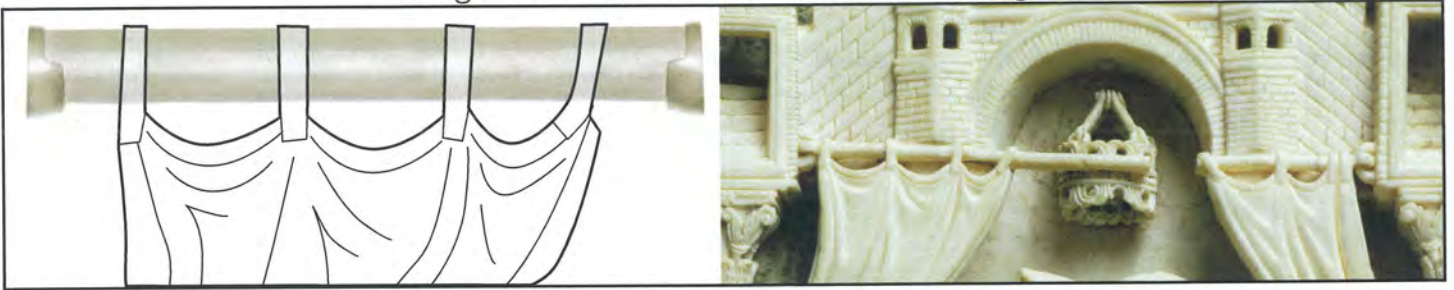

Cafe/Shower Bracket®
BR_CAW, pair;
Rtn: 7/8"
2 1/2"W X 2 1/2"H X 1"L



1 3/4" Smooth Wood Rod®
12" RO_21W 72" RO_26W
24" RO_22W 96" RO_28W
36" RO_23W Custom Cut for rods under 8'6" CUT FEE
48" RO_24W extra long 1 3/4" Smooth Wood Rods over
8' RO_2CW per foot

image 11 - hand forged nails

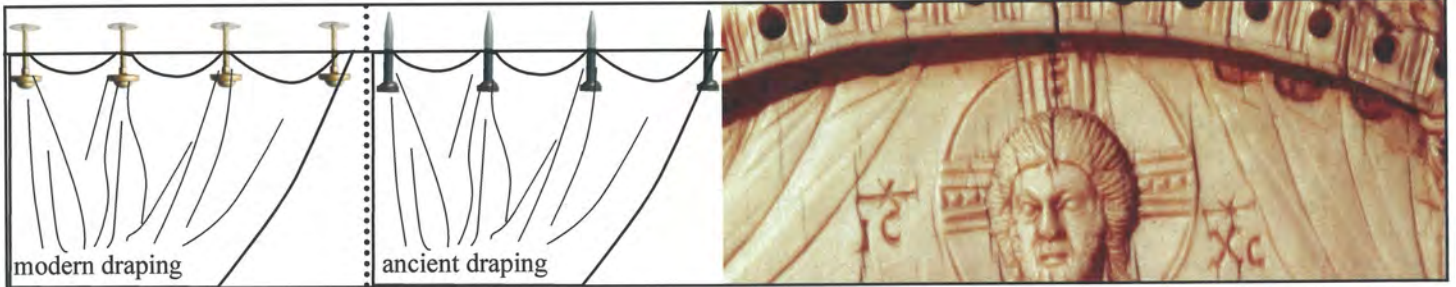

Hand Forged Nail® Round BR_HFN,
single; 3 1/4" long; 7/8" HEAD DIAM
EXTRUDES FROM WALL APPROX. 2"



Hand Forged Nail® Screw BR_HFS
single; 7/8" HEAD DIAM
EXTRUDES FROM WALL APPROX. 1"



Serenity 2® Medallion
BR_S2W, pair
Rtn: 2 1/2"; 2 1/2" DIA X 1"L

image 12 - hand forged nails

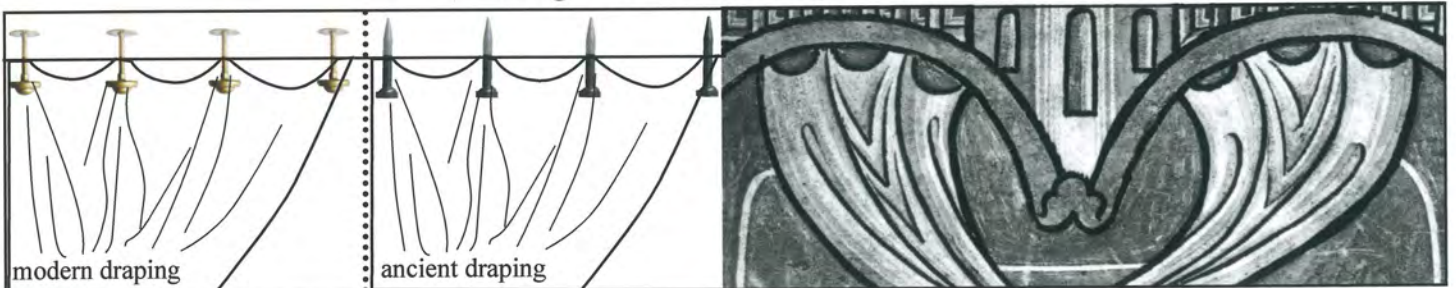

Hand Forged Nail® Round BR_HFN,
single; 3 1/4" long; 7/8" HEAD DIAM
EXTRUDES FROM WALL APPROX. 2"



Hand Forged Nail® Screw BR_HFS
single; 7/8" HEAD DIAM
EXTRUDES FROM WALL APPROX. 1"



Serenity 2® Medallion
BR_S2W, pair
Rtn: 2 1/2"; 2 1/2" DIA X 1"L

image 13 - swing arms rods, finial and iron rings

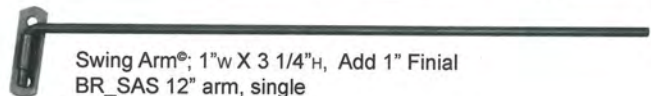
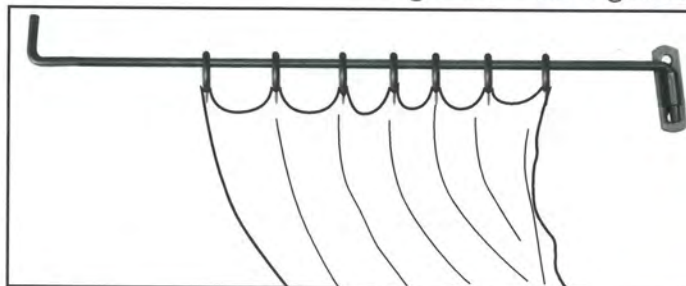

Swing Arm®; 1" w X 3 1/4" h, Add 1" Finial
 BR_SAS 12" arm, single
 BR_SAM 18" arm, single
 BR_SAL 22" arm, single



Virage® Finial
 FI_SRM, single
 1/3" w X 2" h X 2" l

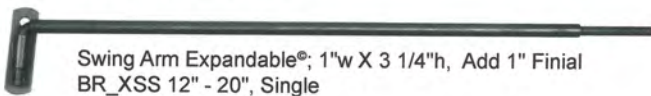

Swing Arm Expandable®; 1" w X 3 1/4" h, Add 1" Finial
 BR_XSS 12" - 20", Single
 BR_XSL 22" - 40", Single
 Custom Swing Arms available



Smooth Iron Rings
 1" RI_ON7, 7 Pk
 1" RI_BXO, 50 Box
 1 1/2" O.D., 1" I.D.

image 14 - cafe bracket, rods and rings



5/8" Round Solid Rod

| | | |
|------------|------------|--|
| 12" RR_10R | 48" RR_40R | 84" RR_70R |
| 18" RR_16R | 54" RR_46R | 90" RR_76R |
| 24" RR_20R | 60" RR_50R | 96" RR_80R |
| 30" RR_26R | 66" RR_56R | 102" RR_86R |
| 36" RR_30R | 72" RR_60R | Custom Cut for rods under 8'6" CUT FEE |
| 42" RR_36R | 78" RR_66R | Available up to 39 feet |



Bamboo Shower®
 Bracket
 BR_BSB, pair
 Rtn: 1/8";
 Base: 2 1/8" DIA.



Mini Cafe Bracket®
 BR_MCF, pair
 Rtn: 1/8";
 Base: 1 1/2" dia.



Smooth Iron Rings
 1" RI_ON7, 7 Pk
 1" RI_BXO, 50 Box
 1 1/2" O.D., 1" I.D.

image 15 - swing arm rods, finial and rings

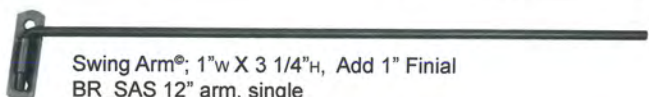
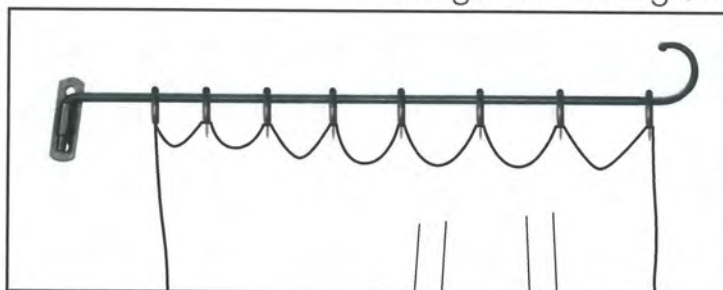

Swing Arm®; 1" w X 3 1/4" h, Add 1" Finial
 BR_SAS 12" arm, single
 BR_SAM 18" arm, single
 BR_SAL 22" arm, single



Ozzie® Finial
 FI_SHC, pair
 1/4" w X 2 1/4" h X 2 1/8" l

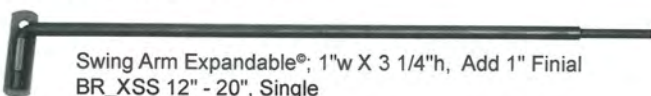

Swing Arm Expandable®; 1" w X 3 1/4" h, Add 1" Finial
 BR_XSS 12" - 20", Single
 BR_XSL 22" - 40", Single
 Custom Swing Arms available



Smooth Iron Rings
 1" RI_ON7, 7 Pk
 1" RI_BXO, 50 Box
 1 1/2" O.D., 1" I.D.

image 16 - ceiling bracket, cafe bracket, rod and rings

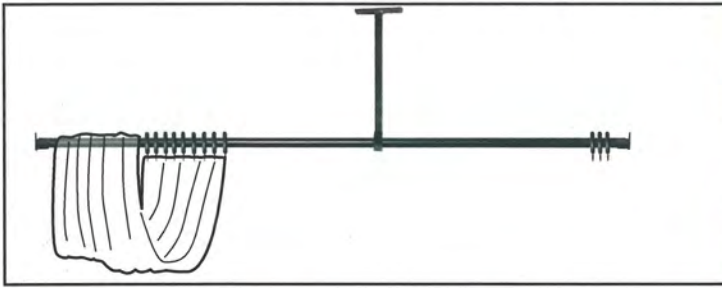

Bamboo Shower®
Bracket
BR_BSB, pair
Rtn: 1/8";
Base: 2 1/8" DIA.



Mini Cafe Bracket®
BR_MCF, pair
Rtn: 1/8";
Base: 1 1/2" dia.



Smooth Iron Rings
1" RI_ON7, 7 Pk
1" RI_BXO, 50 Box
1 1/2" O.D., 1" I.D.



5/8" Round Solid Rod

| | |
|------------|------------|
| 12" RR_10R | 48" RR_40R |
| 18" RR_16R | 54" RR_46R |
| 24" RR_20R | 60" RR_50R |
| 30" RR_26R | 66" RR_56R |
| 36" RR_30R | 72" RR_60R |
| 42" RR_36R | 78" RR_66R |

| |
|-------------|
| 84" RR_70R |
| 90" RR_76R |
| 96" RR_80R |
| 102" RR_86R |

Custom Cut for rods under 8'6" CUT FEE
Available up to 39 feet

image 17 - cafe bracket, ceiling bracket and rod

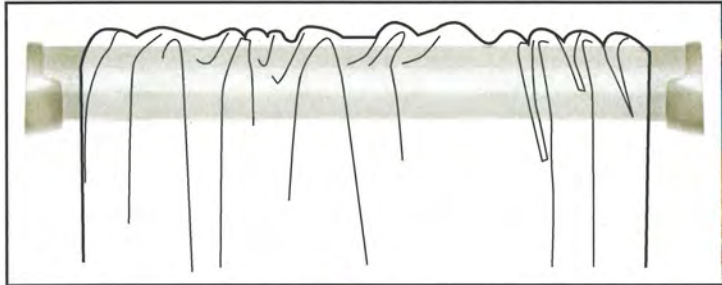

Cafe/Shower Bracket®
BR_CAW, pair;
Rtn: 7/8"
2 1/2"w X 2 1/2"h X 1"



Ceiling Tube Bracket©
BR_CTEA, pair
Rtn: 3"; 2 1/2"w X 3 1/4"h X 4"l
May also be used as wall mount.
"Mullion base": attach to a stud,
ceiling rafter or professionally install.



1 3/4" Smooth Wood Rod®

| | |
|------------|------------|
| 12" RO_21W | 48" RO_24W |
| 24" RO_22W | 72" RO_26W |
| 36" RO_23W | 96" RO_28W |

Custom Cut for rods under 8'6"
CUT FEE

extra long 1 3/4" Smooth Wood
Rods over 8' RO_2CW per foot

image 18 - cafe bracket, rods and rings

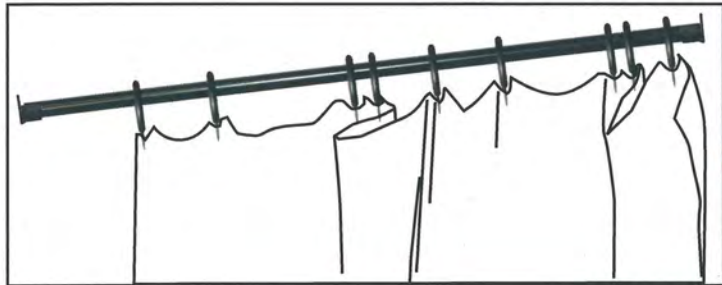

Bamboo Shower®
Bracket
BR_BSB, pair
Rtn: 1/8";
Base: 2 1/8" DIA.



Mini Cafe Bracket®
BR_MCF, pair
Rtn: 1/8";
Base: 1 1/2" dia.



Smooth Iron Rings
1" RI_ON7, 7 Pk
1" RI_BXO, 50 Box
1 1/2" O.D., 1" I.D.



5/8" Round Solid Rod

| | |
|------------|------------|
| 12" RR_10R | 48" RR_40R |
| 18" RR_16R | 54" RR_46R |
| 24" RR_20R | 60" RR_50R |
| 30" RR_26R | 66" RR_56R |
| 36" RR_30R | 72" RR_60R |
| 42" RR_36R | 78" RR_66R |

| |
|-------------|
| 84" RR_70R |
| 90" RR_76R |
| 96" RR_80R |
| 102" RR_86R |

Custom Cut for rods under 8'6" CUT FEE
Available up to 39 feet

image 19 - cafe brackets, rods and rings

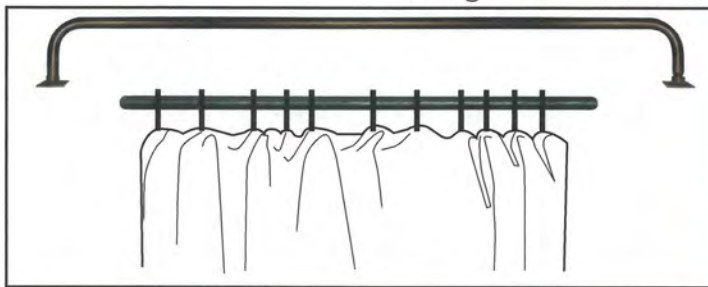

Hotel Artistes rod 3 1/4" return
RR_CHRS



5/8" Rod C Rings Smooth 2"
RI_58C, Bag of 7
2" O.D., 1 1/2" I.D.



5/8" Rod C Ring with welded wand
36" AC_7S2, single
60" AC_7S4, single
Special cut, AC_7SC, each



Hotel Artistes rod 6" return
RR_CHR6



Universal Hinged® Tieback
BR_HTB, pair;
Rtn 5"; 13"W X 5" DEEP
May add 1" finials to end. Shown with
Angelica FI_AN1, pair

Custom hand forged length up to 39 feet

image 20 - cafe brackets, rods and rings

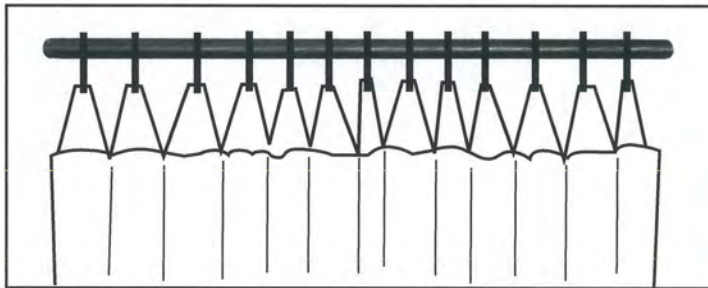

5/8" Round Solid Rod

| | | |
|------------|------------|--|
| 12" RR_10R | 48" RR_40R | 84" RR_70R |
| 18" RR_16R | 54" RR_46R | 90" RR_76R |
| 24" RR_20R | 60" RR_50R | 96" RR_80R |
| 30" RR_26R | 66" RR_56R | 102" RR_86R |
| 36" RR_30R | 72" RR_60R | Custom Cut for rods under 8'6" CUT FEE |
| 42" RR_36R | 78" RR_66R | Available up to 39 feet |



Bamboo Shower®
Bracket
BR_BSB, pair
Rtn: 1/8";
Base: 2 1/8" DIA.



Mini Cafe Bracket®
BR_MCF, pair
Rtn: 1/8";
Base: 1 1/2" dia.



Smooth Iron Rings
1" RI_ON7, 7 Pk
1" RI_BXO, 50 Box
1 1/2" O.D., 1" I.D.

image 21 - cafe brackets, rods and rings

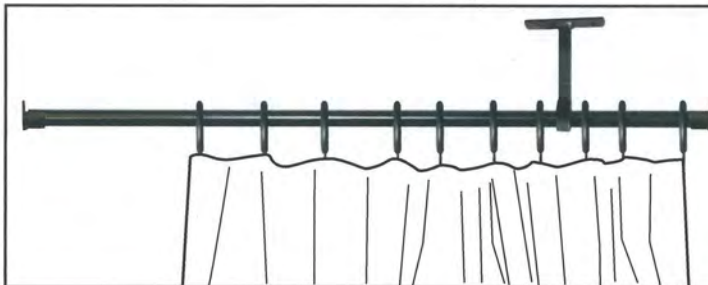

5/8" Round Solid Rod

| | | |
|------------|------------|--|
| 12" RR_10R | 48" RR_40R | 84" RR_70R |
| 18" RR_16R | 54" RR_46R | 90" RR_76R |
| 24" RR_20R | 60" RR_50R | 96" RR_80R |
| 30" RR_26R | 66" RR_56R | 102" RR_86R |
| 36" RR_30R | 72" RR_60R | Custom Cut for rods under 8'6" CUT FEE |
| 42" RR_36R | 78" RR_66R | Available up to 39 feet |



Bamboo Shower®
Bracket
BR_BSB, pair
Rtn: 1/8";
Base: 2 1/8" DIA.



Mini Cafe Bracket®
BR_MCF, pair
Rtn: 1/8";
Base: 1 1/2" dia.



Smooth Iron Rings
1" RI_ON7, 7 Pk
1" RI_BXO, 50 Box
1 1/2" O.D., 1" I.D.

image 22 - cafe brackets, rods and rings

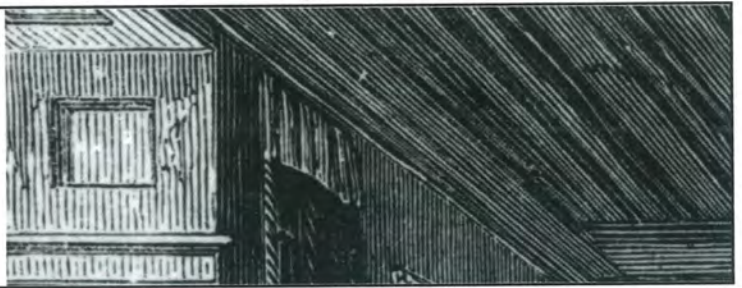
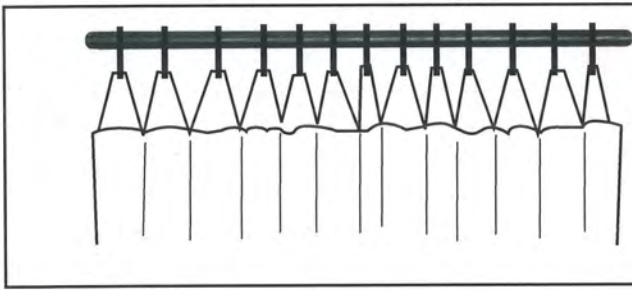

Bamboo Shower®
Bracket
BR_BSB, pair
Rtn: 1/8";
Base: 2 1/8" DIA.



Mini Cafe Bracket®
BR_MCF, pair
Rtn: 1/8";
Base: 1 1/2" dia.



Smooth Iron Rings
1" RI_ON7, 7 Pk
1" RI_BXO, 50 Box
1 1/2" O.D., 1" I.D.



5/8" Round Solid Rod

| | | |
|------------|------------|--|
| 12" RR_10R | 48" RR_40R | 84" RR_70R |
| 18" RR_16R | 54" RR_46R | 90" RR_76R |
| 24" RR_20R | 60" RR_50R | 96" RR_80R |
| 30" RR_26R | 66" RR_56R | 102" RR_86R |
| 36" RR_30R | 72" RR_60R | Custom Cut for rods under 8'6" CUT FEE |
| 42" RR_36R | 78" RR_66R | Available up to 39 feet |

image 23 - radius rods

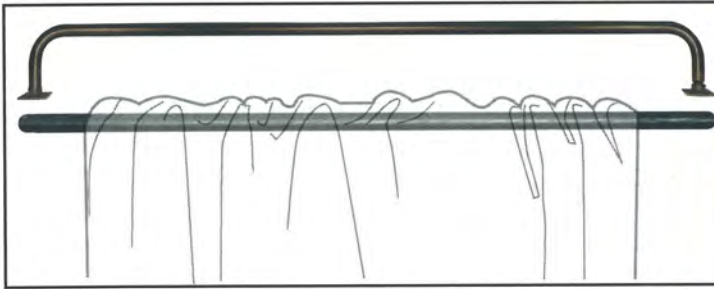

Hotel Artistes rod 3 1/4" return
RR_CHRS



Hotel Artistes rod 6" return
RR_CHR6

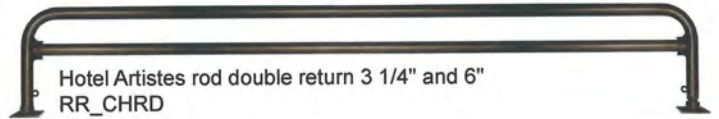

Hotel Artistes rod double return 3 1/4" and 6"
RR_CHRD

Custom hand forged length up to 39 feet

image 24 - cafe bracket and rod

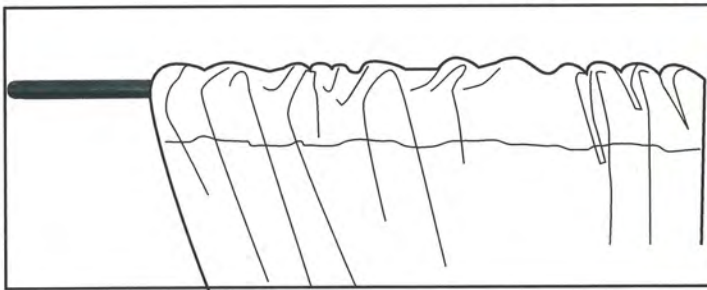

Cafe/Shower Bracket®
BR_CAW, pair;
Rtn: 7/8"
2 1/2"w X 2 1/2"h X 1"



1 3/4" Smooth Wood Rod®

| | | |
|------------|------------|--|
| 12" RO_21W | 48" RO_24W | Custom Cut for rods under 8'6" CUT FEE |
| 24" RO_22W | 72" RO_26W | extra long 1 3/4" Smooth Wood |
| 36" RO_23W | 96" RO_28W | Rods over 8' RO_2CW per foot |

1" scale iron rods



7/8" Round Hollow Rod; comes with plugs USA ⚡

| | | |
|------------|------------|--------------------------------|
| 12" RR_10H | 48" RR_40H | 84" RR_70H |
| 18" RR_16H | 54" RR_46H | 90" RR_76H |
| 24" RR_20H | 60" RR_50H | 96" RR_80H |
| 30" RR_26H | 66" RR_56H | 102" RR_86H |
| 36" RR_30H | 72" RR_60H | Custom Cut for rods under 8'6" |
| 42" RR_36H | 78" RR_66H | CUT FEE |



3/4" Rope Twist Solid Steel Rod USA ⚡

| | | |
|------------|------------|--------------------------------|
| 12" R3_10R | 48" R3_40R | 84" R3_70R |
| 18" R3_16R | 54" R3_46R | 90" R3_76R |
| 24" R3_20R | 60" R3_50R | 96" R3_80R |
| 30" R3_26R | 66" R3_56R | 102" R3_86R |
| 36" R3_30R | 72" R3_60R | Custom Cut for rods under 8'6" |
| 42" R3_36R | 78" R3_66R | CUT FEE |



3/4" Single Twist Solid Steel Rod USA ⚡

| | | |
|------------|------------|--------------------------------|
| 12" R3_10S | 48" R3_40S | 84" R3_70S |
| 18" R3_16S | 54" R3_46S | 90" R3_76S |
| 24" R3_20S | 60" R3_50S | 96" R3_80S |
| 30" R3_26S | 66" R3_56S | 102" R3_86S |
| 36" R3_30S | 72" R3_60S | Custom Cut for rods under 8'6" |
| 42" R3_36S | 78" R3_66S | CUT FEE |



5/8" Double Twist Solid Rod USA ⚡

| | | |
|------------|------------|--------------------------------|
| 12" RO_10D | 48" RO_40D | 84" RO_70D |
| 18" RO_16D | 54" RO_46D | 90" RO_76D |
| 24" RO_20D | 60" RO_50D | 96" RO_80D |
| 30" RO_26D | 66" RO_56D | 102" RO_86D |
| 36" RO_30D | 72" RO_60D | Custom Cut for rods under 8'6" |
| 42" RO_36D | 78" RO_66D | CUT FEE |



5/8" Single Twist Solid Rod USA ⚡

| | | |
|------------|------------|--------------------------------|
| 12" RO_10S | 48" RO_40S | 84" RO_70S |
| 18" RO_16S | 54" RO_46S | 90" RO_76S |
| 24" RO_20S | 60" RO_50S | 96" RO_80S |
| 30" RO_26S | 66" RO_56S | 102" RO_86S |
| 36" RO_30S | 72" RO_60S | Custom Cut for rods under 8'6" |
| 42" RO_36S | 78" RO_66S | CUT FEE |



5/8" Round Solid Rod USA ⚡

| | | |
|------------|------------|--------------------------------|
| 12" RR_10R | 48" RR_40R | 84" RR_70R |
| 18" RR_16R | 54" RR_46R | 90" RR_76R |
| 24" RR_20R | 60" RR_50R | 96" RR_80R |
| 30" RR_26R | 66" RR_56R | 102" RR_86R |
| 36" RR_30R | 72" RR_60R | Custom Cut for rods under 8'6" |
| 42" RR_36R | 78" RR_66R | CUT FEE |



1/3" Twisted Tapestry Rod USA ⚡

| | | |
|------------|------------|--------------------------------|
| 12" RO_10T | 48" RO_40T | 84" RO_70T |
| 18" RO_16T | 54" RO_46T | 90" RO_76T |
| 24" RO_20T | 60" RO_50T | 96" RO_80T |
| 30" RO_26T | 66" RO_56T | 102" RO_86T |
| 36" RO_30T | 72" RO_60T | Custom Cut for rods under 8'6" |
| 42" RO_36T | 78" RO_66T | CUT FEE |



1/4" Round Tapestry Rod USA ⚡

| | | |
|------------|------------|--------------------------------|
| 12" RR_10T | 48" RR_40T | 84" RR_70T |
| 18" RR_16T | 54" RR_46T | 90" RR_76T |
| 24" RR_20T | 60" RR_50T | 96" RR_80T |
| 30" RR_26T | 66" RR_56T | 102" RR_86T |
| 36" RR_30T | 72" RR_60T | Custom Cut for rods under 8'6" |
| 42" RR_36T | 78" RR_66T | CUT FEE |

extra long rods 8'6" to 24'
motor freight fee (continental U.S.A.) • contact customer service for rods up to 39 feet



7/8" Round Hollow Rod;
comes with plugs
RR_O4H per ft
USA ⚡



3/4" Rope Twist Solid
Iron Rod
R3_O4R per ft
USA ⚡



3/4" Single Twist Solid
Iron Rod
R3_O4S per ft
USA ⚡



5/8" Double Twist
Solid Iron Rod
RO_O4D per ft
USA ⚡

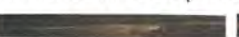

5/8" Single Twist Solid
Iron Rod
RO_O4S per ft
USA ⚡



5/8" Round Solid Iron
Rod
RR_O4R per ft
USA ⚡

1" scale rod accessories



Connector Screws
ACBSCR Pair



Hinged Corner Rod®
7/8" Hollow, AC_HCH, single



Hinged Corner Rod®
5/8" Line, AC_HCR, single



Ring Glide Tape for 1" scale rods
ACTAP1, 8' length
Apply to top of any rod to help rings slide
smoothly on functioning treatments.

1" scale iron rings



Smooth Iron Rings
1" RI_ON7, 7 Pk
1" RI_BXO, 50 Box
1 1/2" O.D., 1" I.D.



Smooth Iron Rings
Croc Clip
1" RI_1C7, 7 pk
1" RI_B1C, 50 bx
1 1/2" O.D., 1" I.D.



Twist Iron Rings
1" RI_1T7, 7 pk
1" RI_1BT, 50 bx
1 1/2" O.D., 1" I.D.



Twist Iron Rings
Croc Clip
1" RI_1R7, 7 pk
1" RI_B1T, 50 bx
1 1/2" O.D., 1" I.D.



Hand Forged Iron Ring
RI_27F, 7 Pk
RI_25F, 50 Box
1 7/8" OD, 1 3/8" I.D.
comes with drapery pins



7/8" Rod C Rings
Smooth 2"
RI_C02, Bag of 7
2" O.D., 1 1/2" I.D.



5/8" Rod C Rings
Smooth 2"
RI_58C, Bag of 7
2" O.D., 1 1/2" I.D.

2" RI_ST7, 7 Pk
2" RI_BXT, 50 Box
2" O.D., 1 1/2" I.D.
comes with drapery pins

2" RI_27C, 7 Pk
2" RI_B2C, 50 Box
2" O.D., 1 1/2" I.D.

2" RI_27T, 7 pk
2" RI_2BT, 50 bx
2" O.D., 1 1/2" I.D.
comes with drapery pins

2" RI_T7C, 7 pk
2" RI_B2T, 50 bx
2" O.D., 1 1/2" I.D.

hand forged lindisfarne abbey collection



ROD: 4' Round Solid Rod RR_40R
 FINIAL: Small Ball® FI_SMB,
 pair; 3/4" w X 3/4" h X 3/4" L
 RINGS: Hand Forged Iron Ring
 RI_27F, 7 Pk; RI_25F, 50 Box

BRACKETS



a) Ceiling Tube Bracket®, BR_CT1, pair; Rtn 3 1/4"; 1" w X 3 1/4" h X 3 1/8" L
 b) 1" Kelly Bracket®, BR_KEL; pair; Rtn 3 1/4"; 1 1/2" w X 1 3/4" h X 3 3/4" L
 c) Tube Towel 3"®, BR_TTS, pair; Rtn 3 1/4"; 2" w X 2 5/8" h X 4" L
 d) 1" Classic Iron®, BR_CLL, pair; Rtn 3 1/4"; Base 2 1/8" DIA.
 e) Stone Base Bracket, BR_LFG, pair; Rtn 3 1/4"

hand forged mission collection



The Mission Bracket
 from a French Cross established during the Crusades.

Brkt Mission Hand Forged® BR_MIS, pair
 Dbl Rtn 3/4" & 3 1/2"; 4 1/2" w X 10" h
 Rod 4' Round Solid Rod RR_40R
 Finial Templar Finial® FI_TEM, pair; 1" w X 2 3/4" h X 7" L



Country French Hook® BR_CFH, pair; Rtn 3"; 7 1/4" w X 3 1/2" DEEP



La Cruz® BR_CRS, pair
 Rtn: 2 1/2"; 4" dia

how to tie backs



Inside Mount Hinged® Tieback; may add 1" finials to end, BR_IMT pair; 7" w x 3" DEEP; may use this tieback without finial

Inside Mount Hinged® Tieback add medallion to end, BR_MMT pair; 7" w x 3" DEEP



Venetian Tieback® Round BR_VON, pair
 Twisted BR_VEN, pair
 Rtn 3", 9" w x 4 1/2" DEEP
 Has 1" clearance for molding.
 May add 1" finials to end.



Universal Hinged® Tieback BR_HTB, pair;
 Rtn 5"; 13" w X 5" DEEP

May add 1" finials to end. Shown with Angelica FI_AN1, pair



Wind® Tieback BR_WIN pair;
 Face 5 1/4" w x 10" h;
 Base 8" w x 1/2" h
 Return from wall 2/38" to 3 3/4" at its widest

how to: ceiling brackets



1" Tribeca Bracket® BR_JK1; pair
 Rtn: 1 3/8";
 Base: 1 7/8" w X 1 1/2" h;
 1 1/2" w X 1 7/8" h X 1 15/16"
 May be ceiling or wall mount
 ↓ USA ↻



1" Broadway C Ring Ceiling Bracket® BR_JKC; single
 Rtn: 1 3/8";
 Base: 1 7/8" w X 1 1/2" h;
 1 1/2" w X 1 7/8" h X 1 15/16"
 FROM CEILING ↓ USA ↻



Ceiling Tube Bracket® BR_CT1, pair
 Rtn: 3 1/4"
 1" w X 3 1/4" h X 3 1/8" L
 ↓ USA ↻



Loft Bracket® 1" BR_LFT1, pair
 Rtn: 3/4"
 1" w X 3 1/4" h X 1 3/8" L



SoHo Bracket® 1" BR_SOH1, pair
 Rtn: 3/4"
 1 1/4" w X 3 1/4" h X 1 3/8" L



Ceiling Bracket® BR_CEI, pair
 Rtn: 1 1/2"
 3 1/4" w X 1" h

tapestry bracket collection



1" Invisible Tapestry® Bracket; BR_12I, pair
 Rtn approx. 1/2"
 1" w x 1 5/16" h



1" Extended Tapestry® Bracket BR_TAP, pair
 Rtn 1 1/2"; 1" w X 1 1/4" h



French Door® BR_FDR, pair
 Rtn 1 1/4"
 2 3/4" w X 2 5/8" h



Italianate Coat Hook® BR_ICH, pair
 Rtn 1/2"; 2" w X 3" h



Italianate French Door® BR_ITP, pair
 Rtn 1/2"
 1" w X 1 3/8" h

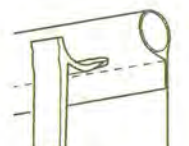

rod pocket tapestries cut opening in pocket for bracket so pocket hangs smoothly

how to Italianate bath



Italianate Bath Tissue Holder®
BR_IBT, single
Face 5 1/2"w x 5 1/2"h



7" No Finial Bath Tissue Rod
AC_07R
7 3/4" long; 5/8" single twist



Italianate Tube/Towel® Bracket
BR_RIT, pair
Rtn 3 1/4"; 1"w X 3 1/4"h



Italianate Coat Hook®
BR_ICH, pair
Rtn 1/2"; 2"w X 3"h

robe hooks



Italianate French Door®
BR_ITP, pair
Rtn 1/2"; 1" w X 1 3/8" h



tissue bar



hand towel



single bath towel

towel bars

| | |
|------------------------------|------------|
| 5/8" Round Solid Rod | |
| Toilet Tissue/Hand Towel Bar | 6" RR_06R |
| Small Single Towel Bar | 12" RR_10R |
| Large Single Towel Bar | 18" RR_16R |
| Double Bath Towel Bar | 24" RR_20R |

how to bordeaux bath



Bordeaux Tissue Holder
BR_BTH; single;
Base 3 1/2"w x 3 1/4"h;
Face 5 1/2"w x 5 1/2"h



7" No Finial Bath Tissue Rod
AC_07R;
7 3/4" long; 5/8" single twist



Bordeaux®
BR_BBR, pair
BR_BO3, pkg of 3
Rtn 3 3/4"; 3 1/2"w X 3 1/8"h X 4 1/4"l



Bordeaux Swag®
BR_BTBP, pair
Rtn 3"
2 1/4"w X 4 3/4"h X 4 1/4"l

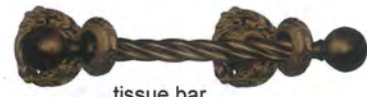

tissue bar



hand towel



single bath towel

towel bars

| | |
|---------------------------------|------------|
| 3/4" Rope Twist Solid Steel Rod | |
| Tissue Bar | 6" R3_06R |
| Hand Towel | 12" R3_10R |
| Single Bath Towel | 18" R3_16R |
| Double Bath Towel | 24" R3_20R |



how to: cafe brackets



Cafe Shower® Bracket
BR_CAF, pair
Rtn: 1/8"; 2"w X 2 5/8"h



Bamboo Shower® Bracket
BR_BSB, pair
Rtn: 1/8"; Base: 2 1/8" dia.



Mini Cafe Bracket®
BR_MCF, pair
Rtn: 1/8"; Base: 1 1/2" dia.



Twist Iron Rings
1" RI_1T7, 7 pk
1" RI_1BT, 50 bx
1 1/2" O.D., 1 1/2" I.D.
comes with drapery pins



Twist Iron Rings
2" RI_2T7, 7 pk
2" RI_2BT, 50 bx
2" O.D., 1 1/2" I.D.
comes with drapery pins; larger ring for
easy opening and closing



Hand Forged Iron Ring
RI_27F, 7 Pk
RI_25F, 50 Box
1 7/8" OD, 1 3/8" I.D.
comes with drapery pins



3/4" Rope Twist Solid Steel Rod
This 3/4" Rope Twist will go longest without center
support based upon weight of product.



5/8" Round Solid Rod



hand forged italianate collection



1" Italianate Double Rod
BR_6IT, single;
DbI Rtn 3 1/4", 6"
1" w X 4 1/2" h X 7 1/4" L

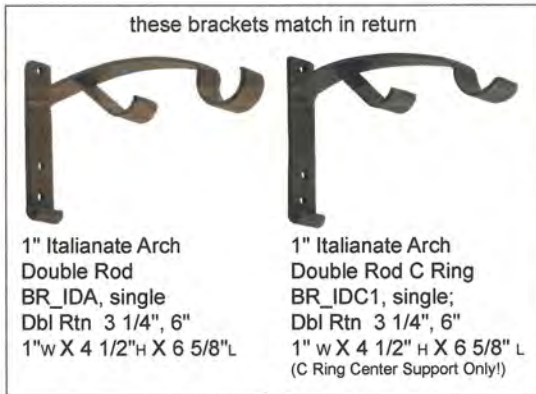

1" Italianate Arch
Double Rod
BR_IDA, single
DbI Rtn 3 1/4", 6"
1" w X 4 1/2" h X 6 5/8" L

1" Italianate Arch
Double Rod C Ring
BR_IDC1, single;
DbI Rtn 3 1/4", 6"
1" w X 4 1/2" h X 6 5/8" L
(C Ring Center Support Only!)

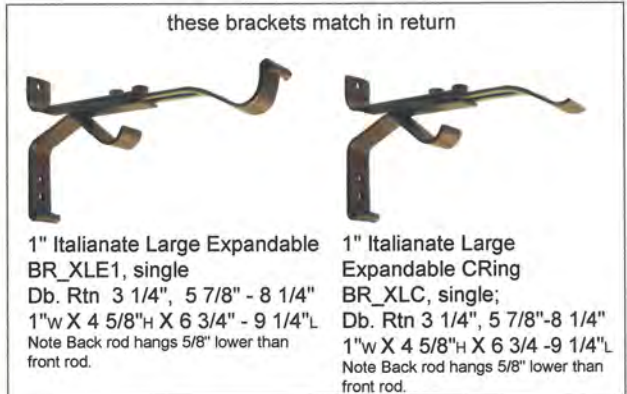

1" Italianate Large Expandable
BR_XLE1, single
Db. Rtn 3 1/4", 5 7/8" - 8 1/4"
1" w X 4 5/8" h X 6 3/4" - 9 1/4" L
Note Back rod hangs 5/8" lower than
front rod.

1" Italianate Large
Expandable CRing
BR_XLC, single;
Db. Rtn 3 1/4", 5 7/8"-8 1/4"
1" w X 4 5/8" h X 6 3/4 -9 1/4" L
Note Back rod hangs 5/8" lower than
front rod.

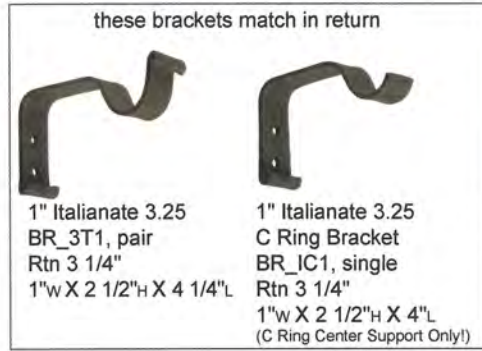

1" Italianate 3.25
BR_3T1, pair
Rtn 3 1/4"
1" w X 2 1/2" h X 4 1/4" L

1" Italianate 3.25
C Ring Bracket
BR_IC1, single
Rtn 3 1/4"
1" w X 2 1/2" h X 4" L
(C Ring Center Support Only!)



Italianate TubeTowel®
BR_RIT, pair
Rtn 3 1/4";
1" w X 3 1/4" h



1" Italianate 5.5
BR_5IT pair; Rtn 5"
1" w X 3 3/8" h X 5 1/2" L



Italianate Coat Hook®
BR_ICH, pair
Rtn 1/2"; 2" w X 3" h



Italianate French Door®
BR_ITP, pair; Rtn 1/2"
1" w X 1 3/8" h

how to french door swing arms



Swing Arm®; 1" w X 3 1/4" h, Add 1" Finial
BR_SAS 12" arm, single
BR_SAM 18" arm, single
BR_SAL 22" arm, single

Swing Arm Expandable®; 1" w X 3 1/4" h, Add 1" Finial
BR_XSS 12" - 20", Single
BR_XSL 22" - 40", Single
Custom Swing Arms available

Suggested finials for swing arms

- *Angelica® 1" FI_AN1, pair; 1 1/2" w X 1 1/2" h X 3" l
- *Birdcage Small Oval® FI_SBC, Pair; 1 3/8" w X 1 3/8" h X 3 3/8" l
- *French Spear® FI_FSP, Pair; 1" w X 3 1/8" h X 5" l
- *Small Ball® FI_SMB, pair; 3/4" w X 3/4" h X 3/4" l
- *Simple Ball® FI_SPB, pair; 1 3/8" w X 1 3/8" h X 1 3/8" l

how to stair hand rail



left center right
1" Italianate Rail Bracket® USA
BR_BNS; set of 3,
Rtn 2 3/4";
Base 2" h X 2 1/4" w;
2 1/4" w X 3 1/4" h X 3 3/8" L
must install in wood stud
professional installation

USA
1" Italianate Rail Support®
BR_BSS; single,
Rtn 2 3/4";
Base 2" h X 2 1/4" w;
2 1/4" w X 3 1/4" h X 3 3/8" L
must install in wood stud
professional installation

- brackets must be secured in wood studs
- we suggest every 16" to 18" or 32" to 36" at studs
- adr suggests professional installation
- check your local housing codes online for proper handrails requirements. improper handrails may affect sale price of house
- adr is not responsible for brackets used as hand rails or towel bars once installed

hotel artistes collection

hand forged 5/8" solid iron rod with detachable base plate to add rings. each rod is custom made for you here in the U.S.A. center supports needed every 4 to 5 feet based upon drapery weight • center supports sold separately • rings sold separately available in unlimited lengths. any length over 8.5 ft requires motor freight fee • contact gcs@antiquedraperyrod.com



Hotel Artistes rod 3 1/4" return ♻️USA ♻️ ♻️
RR_CHRS

There is only one product code for this product. Your exact outside dimensions are required. See back page for bracket dimensions.

Per linear foot
over 8' rod length requires motor freight shipping (Continental US)
does not include support brackets which must be added every 4' to 6' based upon fabric weight. these are custom made to order.



detachable right bracket



1" Modern Tube/Towel Bracket
BR_MTT, pair
Rtn 3 1/4"; 1" w X 2 1/4" h X 4" L
♻️USA ♻️ ♻️



1" Modern 3.25 C Ring Bracket
BR_1MC, single
Rtn 3 1/4"; 1" w X 2 1/4" h X 4" L
(For C Ring Center Support Only!)
♻️USA ♻️ ♻️



1" Neo Tube/Towel Mullion Bracket
BR_1MR, pair
Rtn 3 1/4"; Base 1" X 3 1/4"
♻️USA ♻️ ♻️



1" Neo 3.25 C Ring Mullion Bracket
BR_1MM, single
Rtn 3 1/4"; Base 1" X 3 1/4"
(For C Ring Center Support Only!)
♻️USA ♻️ ♻️



Hotel Artistes rod 6" return ♻️USA ♻️ ♻️
RR_CHR6

There is only one product code for this product. Your exact outside dimensions are required. See back page for bracket dimensions.

Per linear foot
over 8' rod length requires motor freight shipping (Continental US)
does not include support brackets which must be added every 4' to 6' based upon fabric weight. these are custom made to order.



detachable right bracket



1" Radius Center Support Single®
BR_6SS, single
Rtn 6"; 1" w x 2 1/4" h x 6 1/2" L
♻️USA ♻️ ♻️



1" Radius Rod C Ring 6" Bracket®
BR_6SC, single
Rtn 6"; 1" w x 2 1/4" h x 6 1/2" L
(For C Ring Center Support Only!)
♻️USA ♻️ ♻️



1" Radius Center Support Mullion Single®
BR_XX2, single
Rtn 6"; Base 2 1/8" DIA.
♻️USA ♻️ ♻️



1" Radius Rod C Ring Mullion 6" Bracket
BR_XX3, single
Rtn 6"; 1" w X 4" h X 6 1/2" L
(For C Ring Center Support Only!)
♻️USA ♻️ ♻️



Hotel Artistes rod double return 3 1/4" and 6" ♻️USA ♻️ ♻️
RR_CHRD

There is only one product code for this product. Your exact outside dimensions are required. See back page for bracket dimensions.

Per linear foot
over 8' rod length requires motor freight shipping (Continental US)
does not include support brackets which must be added every 4' to 6' based upon fabric weight. These are custom made to order.



detachable right bracket



1" Modern Double Rod Bracket
BR_MD, pair
Dbl Rtn 3 1/4", 6"
1" w X 4" h X 6 1/2" L
♻️USA ♻️ ♻️



1" Simplicity C Ring Bracket
BR_SC, single
Dbl Rtn 3 1/4", 6"
1" w X 4" h X 6 1/2" L
(For C Ring Center Support Only!)
♻️USA ♻️ ♻️



1" Modern Double Rod Mullion Bracket
BR_S3Y, single
Dbl Rtn 3 1/4", 6"
1" w X 4" h X 6 1/2" L
♻️USA ♻️ ♻️



1" Radius Double Rod C Ring Mullion Bracket
BR_S4Y, single
Dbl Rtn 3 1/4", 6"
1" w X 4" h X 6 1/2" L
(For C Ring Center Support Only!)
♻️USA ♻️ ♻️

2" scale wood rods



1 3/4" Carved Wood Rod® USA ♻️ ECO
 12" RO_11W 72" RO_16W
 24" RO_12W 96" RO_18W
 24" RO_13W Custom Cut for rods under
 48" RO_14W 8'6" CUT FEE



1 3/4" Smooth Wood Rod® USA ♻️ ECO
 12" RO_21W 72" RO_26W
 24" RO_22W 96" RO_28W
 36" RO_23W Custom Cut for rods under
 48" RO_24W 8'6" CUT FEE



1 3/4" Fluted Wood Rod® USA ♻️ ECO
 12" RO_31W 72" RO_36W
 24" RO_32W 96" RO_38W
 36" RO_33W Custom Cut for rods under
 48" RO_34W 8'6" CUT FEE



1 3/4" Round Hollow Iron Rod USA ♻️
 12" RR_102 42" RR_362 72" RR_602
 18" RR_162 48" RR_402 78" RR_662
 24" RR_202 54" RR_462 84" RR_702
 30" RR_262 60" RR_502 90" RR_762
 36" RR_302 66" RR_562 96" RR_802

102" RR_862
 Custom Cut for rods
 under 8'6" CUT FEE
 retail



2" Tortoise Shell and Painted Bamboo (code "T" for Tortoise Shell)
 12" BB_102 42" BB_362 72" BB_602 102" BB_862
 18" BB_162 48" BB_402 78" BB_662
 24" BB_202 54" BB_462 84" BB_702
 30" BB_262 60" BB_502 90" BB_762
 36" BB_302 66" BB_562 96" BB_802
 Custom Cut for rods
 under 8'6" CUT FEE
 USA ♻️ ECO

extra long rods 8'6" to 24'

motor freight fee (continental U.S.A.)



extra long 1 3/4" Carved Wood Rods
 over 8' RO_1CW Sold per foot



extra long 1 3/4" Smooth Wood Rods
 over 8' RO_2CW Sold per foot



extra long 1 3/4" Fluted Wood Rods
 over 8' RO_3CW Sold per foot



extra long 1 3/4" Painted Metal Rods
 over 8' RR_O42 per foot



extra long 2" Tortoise Shell and
 Painted Bamboo Rods
 over 8'6" BB_SC2 per foot

2" scale rings



3" Ring
 RI_17W, 7 Pk
 RI_BNW, 50 Box
 3 1/4" OD, 2 1/4" ID
 comes with drapery pins



3" Ring with Croc Clip
 RI_C7W, 7 Pk
 RI_B1W, 50 Box
 3 1/4" OD, 2 1/4" ID



Beaded 3" Ring
 RI_B7W, 7 Pk
 RI_B50, 50 Box
 3 1/2" OD, 2 1/8" ID
 comes with drapery pins



Oversized Ring
 RI_30W 6 Pk
 3 5/8" OD, 2 5/8" ID
 comes with drapery pins



Oversized C Ring
 for use with 2" Rods
 RI_30C; 7 pk
 comes with drapery pins



3" Iron Straight Ring
 RI_37T, 7 Pk;
 RI_BS3, 50 Bx;
 3" OD, 2 1/2" ID
 comes with drapery pins



Hand Forged Iron Ring
 RI_37F, 7 Pk
 RI_35F, 50 Box
 3 1/8" OD, 2 5/8" ID
 comes with drapery pins

2" scale rod accessories



2" Connector Screws
 for wood rods
 ACACSW; pair



Hinged Corner Rod®
 2" Line, AC_HCW, single



Ring Glide Tape
 ACTAPE, 8' length
 Apply to top of any rod to
 help rings slide smoothly on
 functioning treatments.

2" scale brackets



USA ♻️
 2" Italianate X-Long Expand.
 C Ring; BR_XLCE, single
 Rtn: 5 1/2" - 9"
 1" W X 5" H X 7" - 10 1/2" L
 (C Ring Center Support Only!)



USA ♻️
 2" Italianate Double Rod
 BR_ID, pair
 Dbl Rtn: 2 1/4", 5 1/2"
 1" W X 5" H X 7" L



USA ♻️
 2" Italianate Double Rod
 C Ring; BR_IDC, single
 Dbl Rtn: 2 1/4", 5 1/2"
 1" W X 3 1/2" H X 6 3/4" L
 (C Ring Center Support Only!)



USA ♻️
 2" Modern Tube/Towel Brkt
 BR_2MTT, pair
 Rtn: 4 1/4"
 1" W X 3 1/4" H X 5" L



USA ♻️
 2" Italianate X-Long
 Expandable BR_XLE, pair
 Rtn: 5 1/2" - 9"
 1" W X 5" H X 7" - 10 1/2" L



USA ♻️
 2" Italianate Round
 BR_IR, pair; Rtn: 4";
 1" W X 3 1/2" H X 5" L



USA ♻️
 2" Grand Italianate
 BR_4IT, pair Rtn: 4"
 1" W X 3 1/2" H X 5" L



USA ♻️
 2" Italianate C Ring
 BR_IC2, single Rtn: 4";
 1" W X 3 1/2" H X 5" L
 (C Ring Center Support Only!)



USA ♻️
 Ceiling Bracket®
 BR_CEA, pair; Rtn: 3"
 3 1/2" W X 3 1/2" H X 2 1/2" L



USA ♻️
 Ceiling C Ring Bracket®
 BR_CCEA, single; Rtn: 3"
 3 1/2" W X 3 1/2" H X 2 1/2" L
 (C Ring Center Support Only!)



USA ♻️
 2" Tribeca Bracket®
 BR_JK2; pair;
 Rtn: 2" from ceiling;
 1/2" W X 3 1/8" H X 2 3/8" L
 BASE: 2 1/2" W X 2" H
 May be wall or ceiling mount.



USA ♻️
 2" Tribeca C Ring
 Ceiling Brkt®
 BR_JA2C; single
 Rtn: 2" from ceiling;
 1/2" W X 3 1/8" H
 BASE: 2 1/2" W X 2" L



USA ♻️
 2" Hudson C Ring
 Wall Brkt®; BR_BRE;
 single; Rtn: 2"
 1/2" W X 1 1/4" H X 2 3/4" L
 BASE: 2" W X 2 1/2" H



USA ♻️
 Ceiling Tube Bracket®
 BR_CTEA, pair Rtn: 3";
 2 1/2" W X 3 1/4" H X 4" L
 May also be used as wall mount.
 *Mullion base; attach to a stud,
 ceiling rafter or professionally install.



USA ♻️
 Cafe/Shower Brkt®
 BR_CAW, pair;
 Rtn: 7/8"
 2 1/2" W X 2 1/2" H X 1" L



USA ♻️
 Wood Rod Tapestry®
 Bracket BR_TP2, pair
 Rtn: 2 3/8"
 1" W X 1 3/4" H X 3 1/4" L
 set screw in bottom

Photo Credits

Bridgeman Art Library International Limited

Cover photo and inside cover photo: image 6; Empress Theodora "Empress Regent" Byzantine Empire, 535 to 548; Pages 8--21 and pages 24 - 65

All other photos, product or otherwise, are the property of Whitney A. Walker

All photography - no reproduction allowed without permission of the above parties.

ABOUT THE AUTHOR



Whitney A. Walker is an environmental, interior and product designer. Ms Walker founded her design firm WAWACO in 1980. Ms Walker founded The Antique Drapery Rod Company in 1992. She is CEO and Chief Product Designer. Products include window hardware, bed hardware, eco responsible drapery panels and custom products for the hospitality, museum and film industry. The Antique Drapery Rod Company Inc specializes in hand forged, hand cast, hand welded and hand painted hardware. ADR produces over 24,000 products in all colorways.

Ms Walker founded Anna Sova Home in 2004 based on responsible product design for a healthy home and planet. This includes Anna Sova Food Paint invented by Ms Walker and her father, Richard K. Walker and patented in 2004. Also the world's most luxurious certified organic cotton and fair trade bed linen, towels and textiles.

Her passion for product design and manufacturing has taken her to factories and production facilities in over 40 countries (in her visits to over 50 countries). During her travels, Ms Walker have visited many of the artworks in this book on location in Paestum, Pompeii Paris, India, Istanbul, Rome, Florence and museums, catacombs, grottoes, and great estates all over the globe.

She credits her interest in product design to the engineers in her family, her father, grandfather and great grandfather (who was a Professor of Engineering at the University of Edinburgh). Ms Walker enjoys the constant search for integrity of material, workmanship and spirit that create harmony in our interiors and our lives.

Made in the USA
Monee, IL
26 August 2021



76596574R00045